

# Innovations Customized

**MRS**<sup>®</sup>  
**MODULAR**  
RACK SYSTEMS PVT LTD

**WALL MOUNT  
RACKS**

**SS  
SERIES**



# Wall Mount Racks SS Series



CERTIFIED

**MRS** offers a versatile range of single section wall mount racks to suit small secured network requirements.

Wall mount racks are the ideal solution where the floor space is a limitation, typical networking equipment like rotors, switches, patch panels, etc. are well accommodated in the rack.

**MRS** single section wall mount racks are fabricated out of C.R.C.A Steel Sheet CNC programmed, punched, bent, welded and powder coated with the highest quality under confirming Industrial, ISO 9001-2015 and 14001-2015 Standards. Manufacturing and quality management systems to ensure the highest quality product.

**MRS** single section wall mount racks are welded frame integrated with side panel / removable side panel, vented top cover with 2 fans and cable entry provision, bottom cover with ventilation and cable entry provision

associated with front toughened glass door along with lock and key and provision to mount on the wall.

**MRS** single section wall mount racks are available from 4 U to 15 U variants with 400, 500, and 600mm deep configuration.

# Wall Mount Racks SS Series

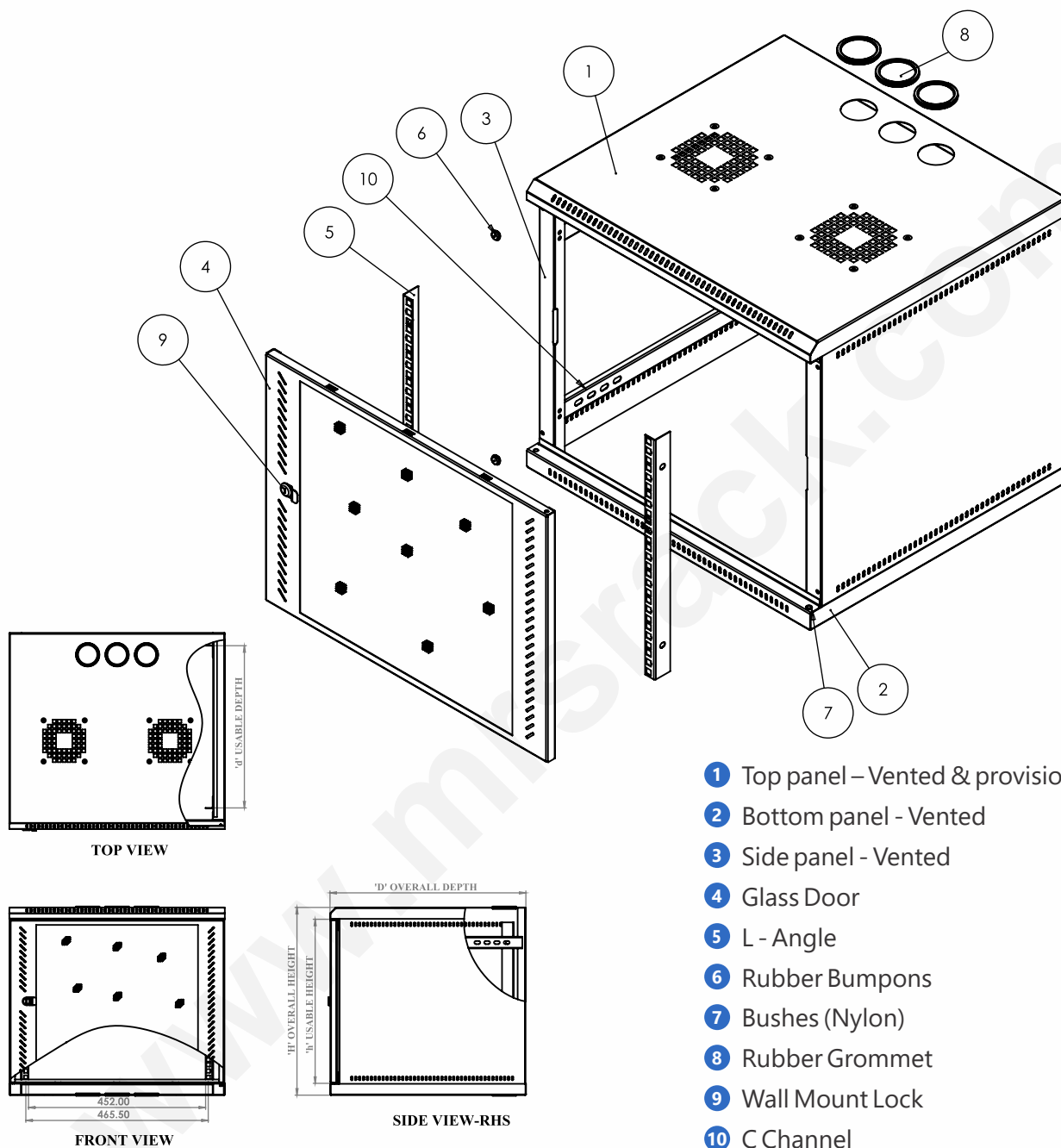

- 1 Top panel – Vented & provision for fan
- 2 Bottom panel - Vented
- 3 Side panel - Vented
- 4 Glass Door
- 5 L - Angle
- 6 Rubber Bumpers
- 7 Bushes (Nylon)
- 8 Rubber Grommet
- 9 Wall Mount Lock
- 10 C Channel

## Product Features

- ◆ Conforms to DIN 41494 OR equivalent ISO Standard.
- ◆ Adjustable 4 nos. 19" angles with punched 10mm square holes and universal 12.7mm. 15.875. Alternating holes format offers for better mounting flexibility and maximizes usable mounting space.
- ◆ Depth adjustable mounting slots.
- ◆ Precision engineering capabilities and best efficient software configuration product technology provide the best product quality and fastest delivery in the industry.
- ◆ Top and bottom Panel with ventilation and cable entry facility.
- ◆ Provision to mount the cooling fans on the top panel.
- ◆ Powder coated finish with 7 Tank pretreatment process meeting ASTM standards.
- ◆ 100% assured compatibility with all equipment conforming to DIN 41494 (General industrial standard for equipment).

### Optional Accessories:

Grounding & Bonding Kit, Power Distribution Box, Instrument Cooling Fans, Cable Manager (Loop / Channel) Cantilever Shelves 250mm.

## ► Technical Data

BASIC FRAME	C.R.C.A Steel Sheet
CONSTRUCTION	Welded
SIDE PANELS	Integrated with top and bottom covers or (Removable type-on-request)
TOP AND BOTTOM PANEL	Vented with fan and cable entry provision
FRONT DOOR	Lockable toughened glass door with ventilation
STANDARD MOUNTING	DIN 41494 10mm. square slot
STANDARD FINISH	Powder Coating
STANDARD COLOR	Dark Grey and Light Grey or Black
STATIC LOAD	40 Kgs

## ► Product Codes and Dimensions

PART CODE	Total Height in MM (H)	Usable Height in U (H)	Total Width in MM (W)	Usable Width in Inches (W)	Total Depth in MM (D)	Usable Depth in MM (D)
<b>MRS-SS-5540-04U</b>	256	04U	550	19"	400	350
<b>MRS-SS-5540-06U</b>	347	06U	550	19"	400	350
<b>MRS-SS-5540-09U</b>	480	09U	550	19"	400	350
<b>MRS-SS-5540-12U</b>	613	12U	550	19"	400	350
<b>MRS-SS-5540-15U</b>	747	15U	550	19"	400	350
<b>MRS-SS-5550-04U</b>	256	04U	550	19"	500	450
<b>MRS-SS-5550-06U</b>	347	06U	550	19"	500	450
<b>MRS-SS-5550-09U</b>	480	09U	550	19"	500	450
<b>MRS-SS-5550-12U</b>	613	12U	550	19"	500	450
<b>MRS-SS-5550-15U</b>	747	15U	550	19"	500	450
<b>MRS-SS-5560-04U</b>	256	04U	550	19"	600	550
<b>MRS-SS-5560-06U</b>	347	06U	550	19"	600	550
<b>MRS-SS-5560-09U</b>	480	09U	550	19"	600	550
<b>MRS-SS-5560-12U</b>	613	12U	550	19"	600	550
<b>MRS-SS-5560-15U</b>	747	15U	550	19"	600	550

1U = 44.45 mm / 1.75 Inch

### Note:

1. Other models can be manufactured on request.
2. It is recommended to distribute the load along with "U" space in the rack.
3. All dimensions are in mm.



### MODULAR RACK SYSTEMS PVT. LTD.

No. 189 & 190, Nadikerappa Industrial Estate, Hegganahalli, Vishwaneedam Post,  
Bangalore-560 091 INDIA • Tel: +91 80 28365042 • Fax: +91 80 28367881  
Mobile: +91 9108220086 • Email: admin@mrsrack.com



# Innovations Customized

**MRS**<sup>®</sup>  
**MODULAR**  
RACK SYSTEMS PVT LTD

**WALL MOUNT  
RACKS**

**SS  
SERIES**



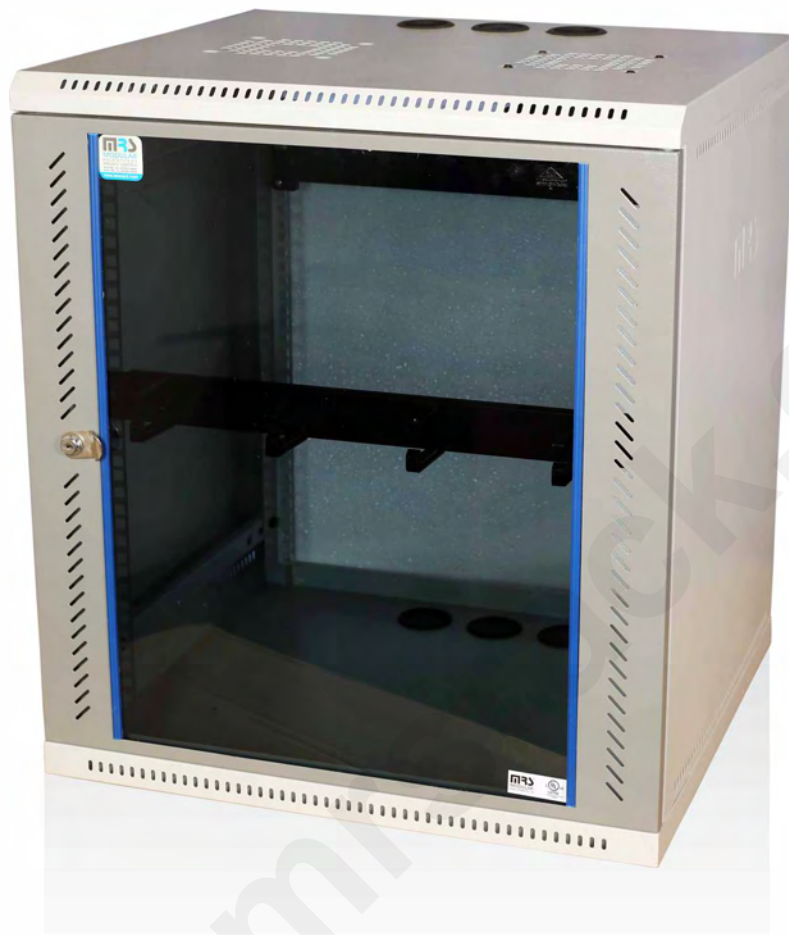

CERTIFIED

**MRS** offers a versatile range of single section wall mount racks to suit small secured network requirements.

Wall mount racks are the ideal solution where the floor space is a limitation, typical networking equipment like rotors, switches, patch panels, etc. are well accommodated in the rack.

**MRS** single section wall mount racks are fabricated out of C.R.C.A Steel Sheet CNC programmed, punched, bent, welded and powder coated with the highest quality under confirming Industrial, ISO 9001-2015 and 14001-2015 Standards. Manufacturing and quality management systems to ensure the highest quality product.

**MRS** single section wall mount racks are welded frame integrated with side panel / removable side panel, vented top cover with 2 fans and cable entry provision, bottom cover with ventilation and cable entry provision

associated with front toughened glass door along with lock and key and provision to mount on the wall.

**MRS** single section wall mount racks are available from 4 U to 15 U variants with 400, 500, and 600mm deep configuration.

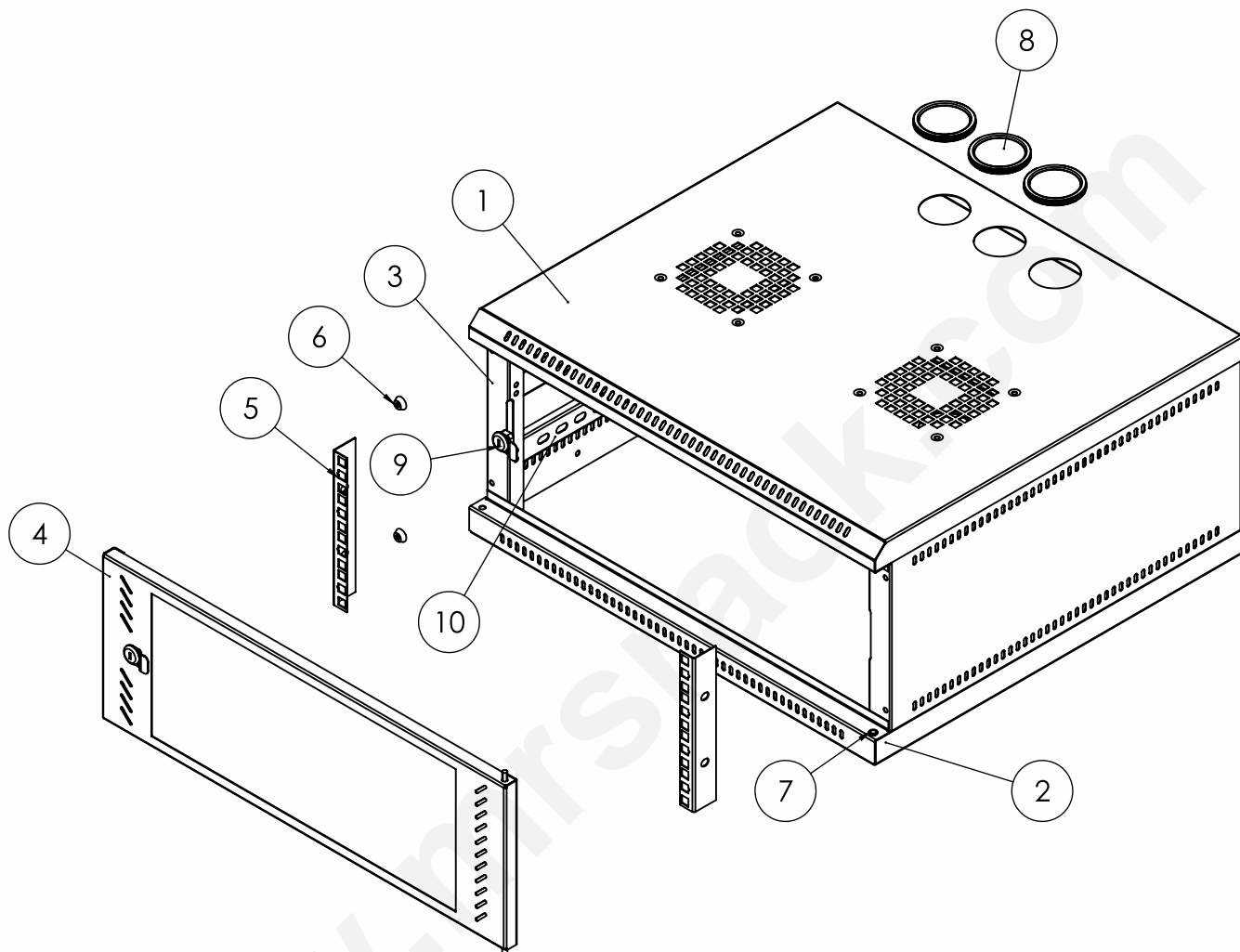

- 1 Top panel – Vented & provision for fan
- 2 Bottom panel - Vented
- 3 Side panel - Vented
- 4 Glass Door
- 5 L - Angle
- 6 Rubber Bumpons
- 7 Bushes (Nylon)
- 8 Rubber Grommet
- 9 Wall Mount Lock
- 10 C Channel

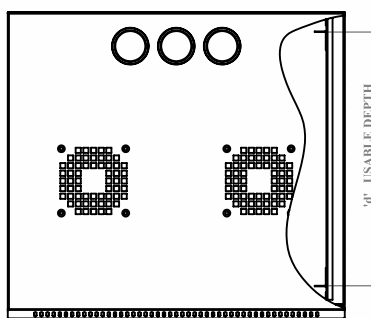

TOP VIEW

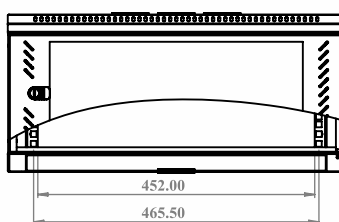

FRONT VIEW

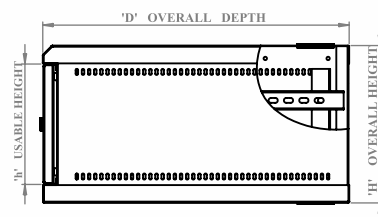

SIDE VIEW - RHS

# Product Features

- ◆ Conforms to DIN 41494 OR equivalent ISO Standard.
- ◆ Adjustable 4 nos. 19" angles with punched 10mm square holes and universal 12.7mm. 15.875. Alternating holes format offers for better mounting flexibility and maximizes usable mounting space.
- ◆ Depth adjustable mounting slots.
- ◆ Precision engineering capabilities and best efficient software configuration product technology provide the best product quality and fastest delivery in the industry.
- ◆ Top and bottom Panel with ventilation and cable entry facility.
- ◆ Provision to mount the cooling fans on the top panel.
- ◆ Powder coated finish with 7 Tank pretreatment process meeting ASTM standards.
- ◆ 100% assured compatibility with all equipment conforming to DIN 41494 (General industrial standard for equipment).

## Optional Accessories:

Grounding & Bonding Kit, Power Distribution Box, Instrument Cooling Fans, Cable Manager (Loop / Channel) Cantilever Shelves 250mm.

## ▶ Technical Data

BASIC FRAME	C.R.C.A Steel Sheet
CONSTRUCTION	Welded
SIDE PANELS	Integrated with top and bottom covers or (Removable type-on-request)
TOP AND BOTTOM PANEL	Vented with fan and cable entry provision
FRONT DOOR	Lockable toughened glass door with ventilation
STANDARD MOUNTING	DIN 41494 10mm. square slot
STANDARD FINISH	Powder Coating
STANDARD COLOR	Dark Grey and Light Grey or Black
STATIC LOAD	40 Kgs

## ▶ Product Codes and Dimensions

PART CODE	Total Height in MM (H)	Usable Height in U (H)	Total Width in MM (W)	Usable Width in Inches (W)	Total Depth in MM (D)	Usable Depth in MM (D)
<b>MRS-SS-5540-04U</b>	256	04U	550	19"	400	350

1U = 44.45 mm / 1.75 Inch

### Note:

1. Other models can be manufactured on request.
2. It is recommended to distribute the load along with "U" space in the rack.
3. All dimensions are in mm.



## MODULAR RACK SYSTEMS PVT. LTD.

No. 189 & 190, Nadikerappa Industrial Estate, Hegganahalli, Vishwaneedam Post,  
Bangalore-560 091 INDIA • Tel: +91 80 28365042 • Fax: +91 80 28367881  
Mobile: +91 9108220086 • Email: admin@mrsrack.com





# Innovations Customized

**MRS**<sup>®</sup>  
**MODULAR**  
RACK SYSTEMS PVT LTD

**WALL MOUNT  
RACKS**

**SS  
SERIES**





CERTIFIED

**MRS** offers a versatile range of single section wall mount racks to suit small secured network requirements.

Wall mount racks are the ideal solution where the floor space is a limitation, typical networking equipment like rotors, switches, patch panels, etc. are well accommodated in the rack.

**MRS** single section wall mount racks are fabricated out of C.R.C.A Steel Sheet CNC programmed, punched, bent, welded and powder coated with the highest quality under confirming Industrial, ISO 9001-2015 and 14001-2015 Standards. Manufacturing and quality management systems to ensure the highest quality product.

**MRS** single section wall mount racks are welded frame integrated with side panel / removable side panel, vented top cover with 2 fans and cable entry provision, bottom cover with ventilation and cable entry provision

associated with front toughened glass door along with lock and key and provision to mount on the wall.

**MRS** single section wall mount racks are available from 4 U to 15 U variants with 400, 500, and 600mm deep configuration.

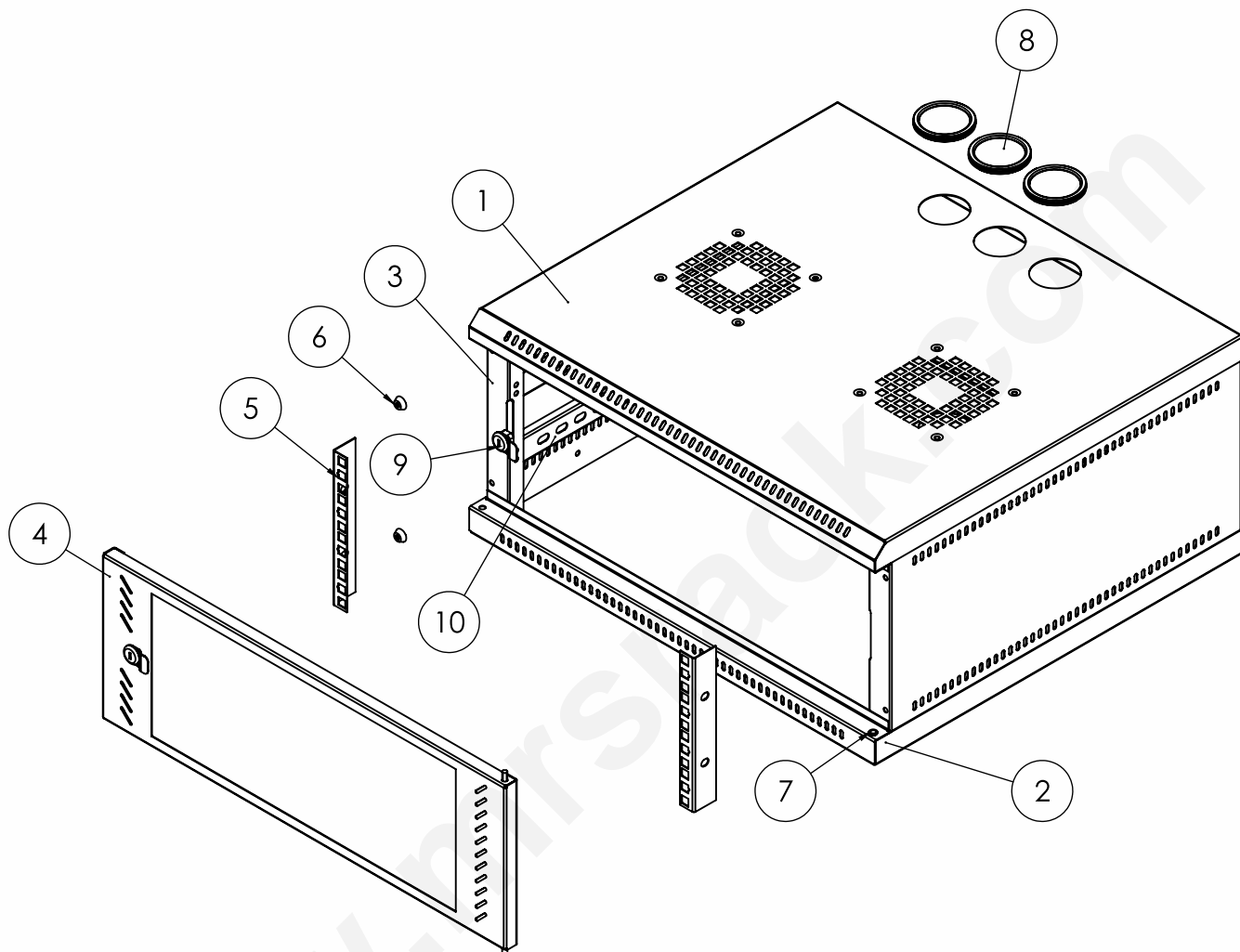

- 1 Top panel – Vented & provision for fan
- 2 Bottom panel - Vented
- 3 Side panel - Vented
- 4 Glass Door
- 5 L - Angle
- 6 Rubber Bumpons
- 7 Bushes (Nylon)
- 8 Rubber Grommet
- 9 Wall Mount Lock
- 10 C Channel

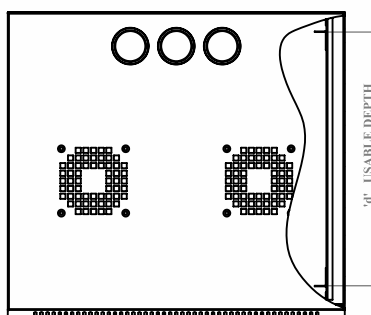

TOP VIEW

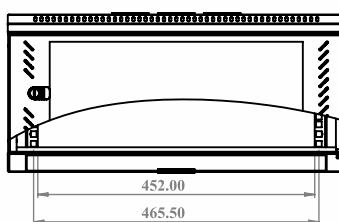

FRONT VIEW

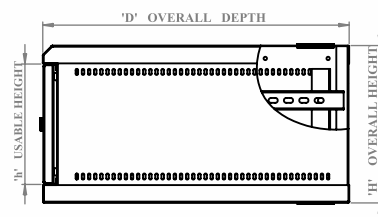

SIDE VIEW - RHS

# Product Features

- ◆ Conforms to DIN 41494 OR equivalent ISO Standard.
- ◆ Adjustable 4 nos. 19" angles with punched 10mm square holes and universal 12.7mm. 15.875. Alternating holes format offers for better mounting flexibility and maximizes usable mounting space.
- ◆ Depth adjustable mounting slots.
- ◆ Precision engineering capabilities and best efficient software configuration product technology provide the best product quality and fastest delivery in the industry.
- ◆ Top and bottom Panel with ventilation and cable entry facility.
- ◆ Provision to mount the cooling fans on the top panel.
- ◆ Powder coated finish with 7 Tank pretreatment process meeting ASTM standards.
- ◆ 100% assured compatibility with all equipment conforming to DIN 41494 (General industrial standard for equipment).

## Optional Accessories:

Grounding & Bonding Kit, Power Distribution Box, Instrument Cooling Fans, Cable Manager (Loop / Channel) Cantilever Shelves 250mm.

## ▶ Technical Data

BASIC FRAME	C.R.C.A Steel Sheet
CONSTRUCTION	Welded
SIDE PANELS	Integrated with top and bottom covers or (Removable type-on-request)
TOP AND BOTTOM PANEL	Vented with fan and cable entry provision
FRONT DOOR	Lockable toughened glass door with ventilation
STANDARD MOUNTING	DIN 41494 10mm. square slot
STANDARD FINISH	Powder Coating
STANDARD COLOR	Dark Grey and Light Grey or Black
STATIC LOAD	40 Kgs

## ▶ Product Codes and Dimensions

PART CODE	Total Height in MM (H)	Usable Height in U (H)	Total Width in MM (W)	Usable Width in Inches (W)	Total Depth in MM (D)	Usable Depth in MM (D)
<b>MRS-SS-5540-06U</b>	347	06U	550	19"	400	350

1U = 44.45 mm / 1.75 Inch

### Note:

1. Other models can be manufactured on request.
2. It is recommended to distribute the load along with "U" space in the rack.
3. All dimensions are in mm.



## MODULAR RACK SYSTEMS PVT. LTD.

No. 189 & 190, Nadikerappa Industrial Estate, Hegganahalli, Vishwaneedam Post,  
Bangalore-560 091 INDIA • Tel: +91 80 28365042 • Fax: +91 80 28367881  
Mobile: +91 9108220086 • Email: admin@mrsrack.com



# Innovations Customized

**MRS**<sup>®</sup>  
**MODULAR**  
RACK SYSTEMS PVT LTD

**WALL MOUNT  
RACKS**

**SS  
SERIES**





CERTIFIED

**MRS** offers a versatile range of single section wall mount racks to suit small secured network requirements.

Wall mount racks are the ideal solution where the floor space is a limitation, typical networking equipment like rotors, switches, patch panels, etc. are well accommodated in the rack.

**MRS** single section wall mount racks are fabricated out of C.R.C.A Steel Sheet CNC programmed, punched, bent, welded and powder coated with the highest quality under confirming Industrial, ISO 9001-2015 and 14001-2015 Standards. Manufacturing and quality management systems to ensure the highest quality product.

**MRS** single section wall mount racks are welded frame integrated with side panel / removable side panel, vented top cover with 2 fans and cable entry provision, bottom cover with ventilation and cable entry provision

associated with front toughened glass door along with lock and key and provision to mount on the wall.

**MRS** single section wall mount racks are available from 4 U to 15 U variants with 400, 500, and 600mm deep configuration.

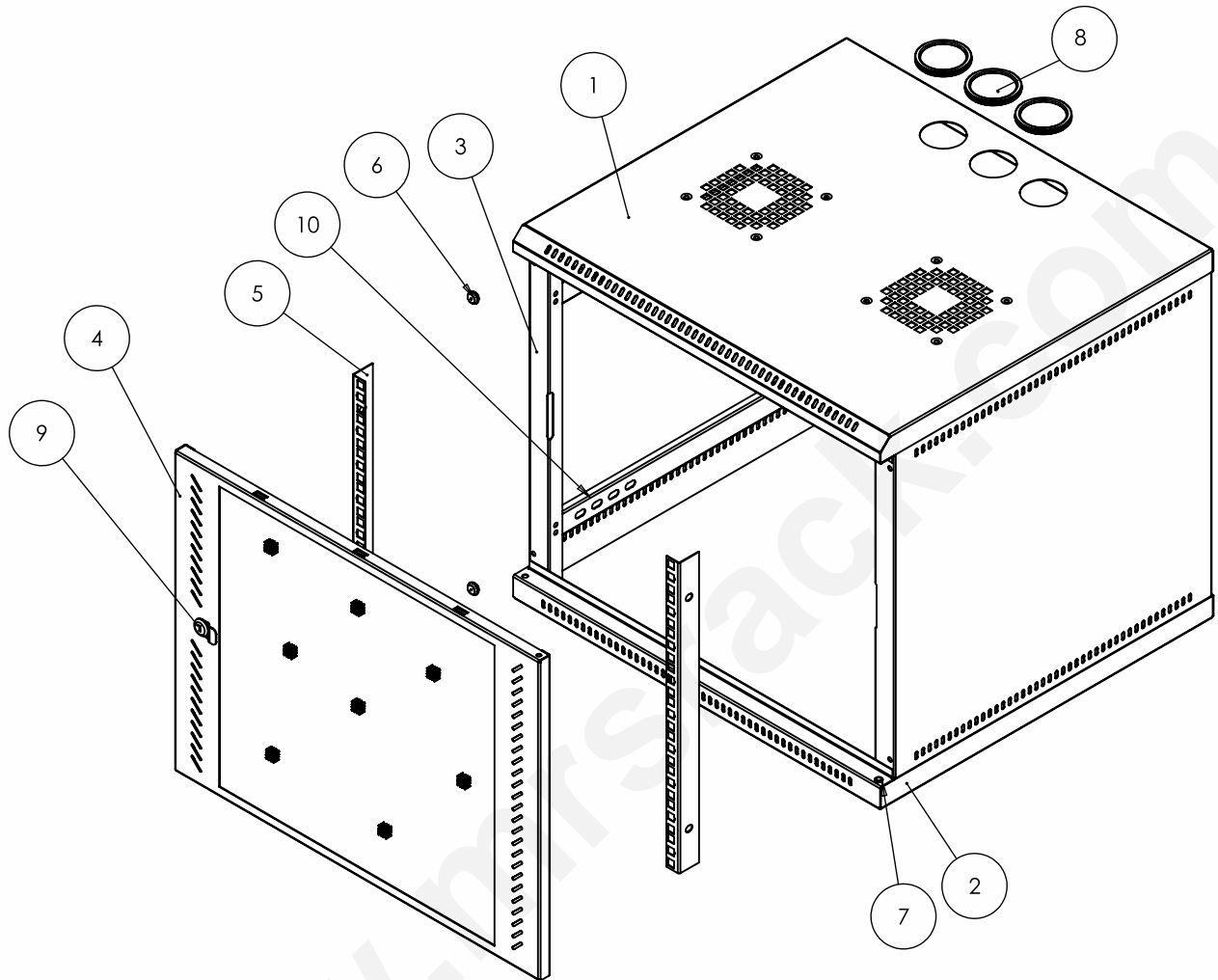

- 1 Top panel – Vented & provision for fan
- 2 Bottom panel - Vented
- 3 Side panel - Vented
- 4 Glass Door
- 5 L - Angle
- 6 Rubber Bump
- 7 Bushes (Nylon)
- 8 Rubber Grommet
- 9 Wall Mount Lock
- 10 C Channel

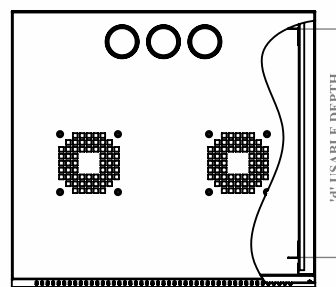

TOP VIEW

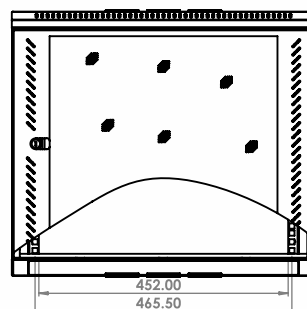

FRONT VIEW

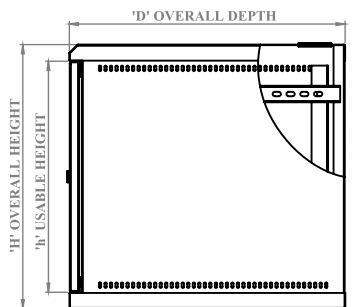

SIDE VIEW-RHS

# Product Features

- ◆ Conforms to DIN 41494 OR equivalent ISO Standard.
- ◆ Adjustable 4 nos. 19" angles with punched 10mm square holes and universal 12.7mm. 15.875. Alternating holes format offers for better mounting flexibility and maximizes usable mounting space.
- ◆ Depth adjustable mounting slots.
- ◆ Precision engineering capabilities and best efficient software configuration product technology provide the best product quality and fastest delivery in the industry.
- ◆ Top and bottom Panel with ventilation and cable entry facility.
- ◆ Provision to mount the cooling fans on the top panel.
- ◆ Powder coated finish with 7 Tank pretreatment process meeting ASTM standards.
- ◆ 100% assured compatibility with all equipment conforming to DIN 41494 (General industrial standard for equipment).

## Optional Accessories:

Grounding & Bonding Kit, Power Distribution Box, Instrument Cooling Fans, Cable Manager (Loop / Channel) Cantilever Shelves 250mm.

## ▶ Technical Data

BASIC FRAME	C.R.C.A Steel Sheet
CONSTRUCTION	Welded
SIDE PANELS	Integrated with top and bottom covers or (Removable type-on-request)
TOP AND BOTTOM PANEL	Vented with fan and cable entry provision
FRONT DOOR	Lockable toughened glass door with ventilation
STANDARD MOUNTING	DIN 41494 10mm. square slot
STANDARD FINISH	Powder Coating
STANDARD COLOR	Dark Grey and Light Grey or Black
STATIC LOAD	40 Kgs

## ▶ Product Codes and Dimensions

PART CODE	Total Height in MM (H)	Usable Height in U (H)	Total Width in MM (W)	Usable Width in Inches (W)	Total Depth in MM (D)	Usable Depth in MM (D)
MRS-SS-5540-09U	480	09U	550	19"	400	350

1U = 44.45 mm / 1.75 Inch

### Note:

1. Other models can be manufactured on request.
2. It is recommended to distribute the load along with "U" space in the rack.
3. All dimensions are in mm.



## MODULAR RACK SYSTEMS PVT. LTD.

No. 189 & 190, Nadikerappa Industrial Estate, Hegganahalli, Vishwaneedam Post,  
Bangalore-560 091 INDIA • Tel: +91 80 28365042 • Fax: +91 80 28367881  
Mobile: +91 9108220086 • Email: admin@mrsrack.com





# Innovations Customized

**MRS**<sup>®</sup>  
**MODULAR**  
RACK SYSTEMS PVT LTD

**WALL MOUNT  
RACKS**

**SS  
SERIES**





**MRS** offers a versatile range of single section wall mount racks to suit small secured network requirements.

Wall mount racks are the ideal solution where the floor space is a limitation, typical networking equipment like rotors, switches, patch panels, etc. are well accommodated in the rack.

**MRS** single section wall mount racks are fabricated out of C.R.C.A Steel Sheet CNC programmed, punched, bent, welded and powder coated with the highest quality under confirming Industrial, ISO 9001-2015 and 14001-2015 Standards. Manufacturing and quality management systems to ensure the highest quality product.

**MRS** single section wall mount racks are welded frame integrated with side panel / removable side panel, vented top cover with 2 fans and cable entry provision, bottom cover with ventilation and cable entry provision

associated with front toughened glass door along with lock and key and provision to mount on the wall.

**MRS** single section wall mount racks are available from 4 U to 15 U variants with 400, 500, and 600mm deep configuration.

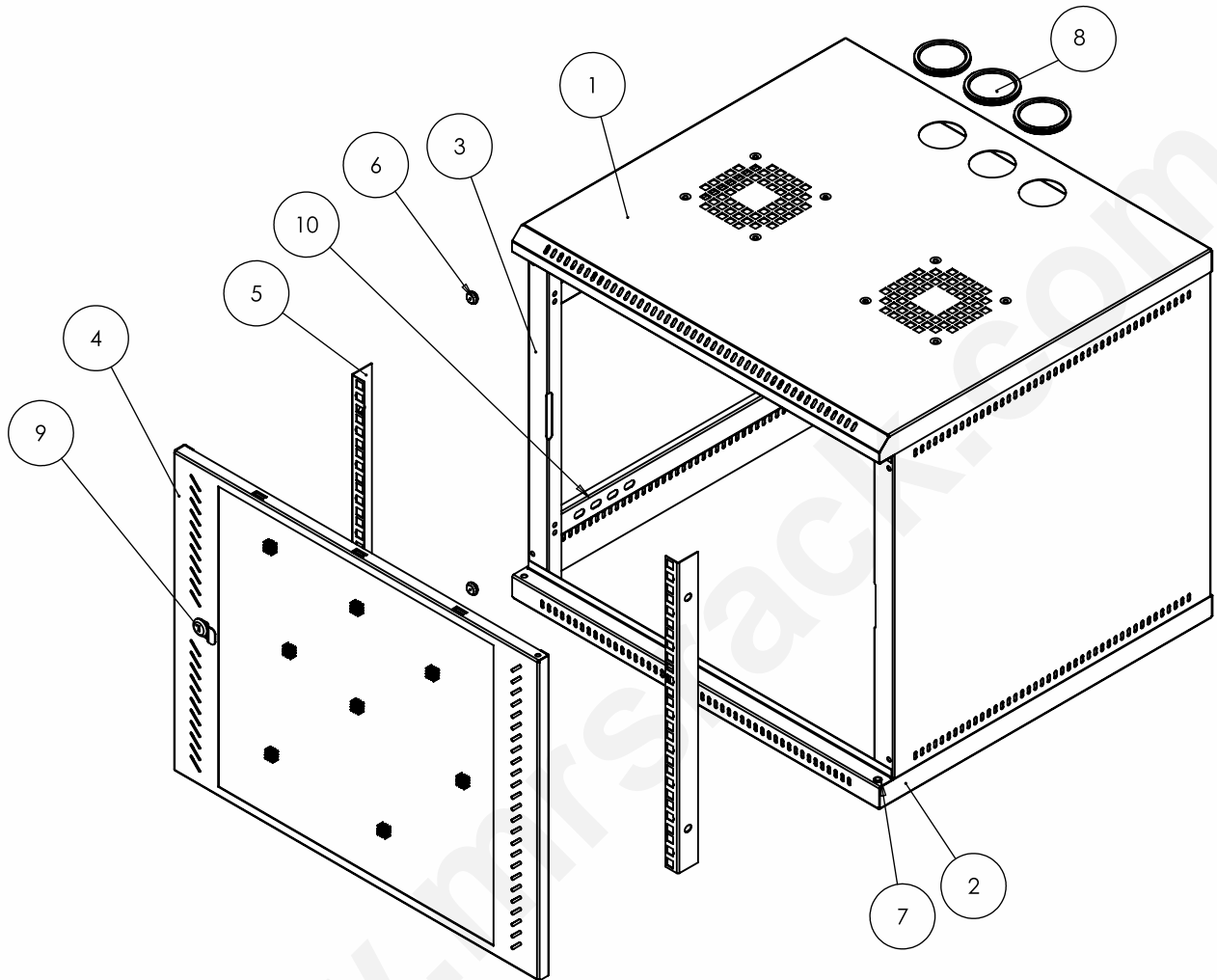

- 1 Top panel – Vented & provision for fan
- 2 Bottom panel - Vented
- 3 Side panel - Vented
- 4 Glass Door
- 5 L - Angle
- 6 Rubber Bumpons
- 7 Bushes (Nylon)
- 8 Rubber Grommet
- 9 Wall Mount Lock
- 10 C Channel

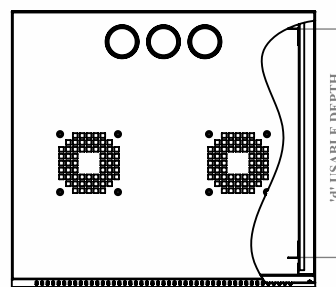

TOP VIEW

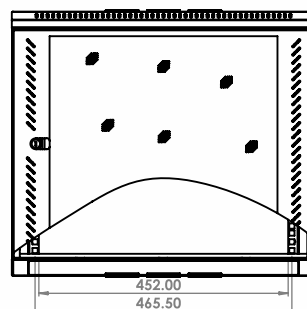

FRONT VIEW

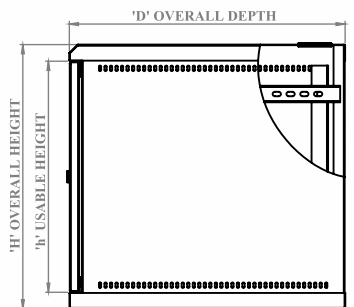

SIDE VIEW-RHS

# Product Features

- ◆ Conforms to DIN 41494 OR equivalent ISO Standard.
- ◆ Adjustable 4 nos. 19" angles with punched 10mm square holes and universal 12.7mm. 15.875. Alternating holes format offers for better mounting flexibility and maximizes usable mounting space.
- ◆ Depth adjustable mounting slots.
- ◆ Precision engineering capabilities and best efficient software configuration product technology provide the best product quality and fastest delivery in the industry.
- ◆ Top and bottom Panel with ventilation and cable entry facility.
- ◆ Provision to mount the cooling fans on the top panel.
- ◆ Powder coated finish with 7 Tank pretreatment process meeting ASTM standards.
- ◆ 100% assured compatibility with all equipment conforming to DIN 41494 (General industrial standard for equipment).

## Optional Accessories:

Grounding & Bonding Kit, Power Distribution Box, Instrument Cooling Fans, Cable Manager (Loop / Channel) Cantilever Shelves 250mm.

## ▶ Technical Data

BASIC FRAME	C.R.C.A Steel Sheet
CONSTRUCTION	Welded
SIDE PANELS	Integrated with top and bottom covers or (Removable type-on-request)
TOP AND BOTTOM PANEL	Vented with fan and cable entry provision
FRONT DOOR	Lockable toughened glass door with ventilation
STANDARD MOUNTING	DIN 41494 10mm. square slot
STANDARD FINISH	Powder Coating
STANDARD COLOR	Dark Grey and Light Grey or Black
STATIC LOAD	40 Kgs

## ▶ Product Codes and Dimensions

PART CODE	Total Height in MM (H)	Usable Height in U (H)	Total Width in MM (W)	Usable Width in Inches (W)	Total Depth in MM (D)	Usable Depth in MM (D)
<b>MRS-SS-5540-12U</b>	613	12U	550	19"	400	350

1U = 44.45 mm / 1.75 Inch

### Note:

1. Other models can be manufactured on request.
2. It is recommended to distribute the load along with "U" space in the rack.
3. All dimensions are in mm.



## MODULAR RACK SYSTEMS PVT. LTD.

No. 189 & 190, Nadikerappa Industrial Estate, Hegganahalli, Vishwaneddam Post,  
Bangalore-560 091 INDIA • Tel: +91 80 28365042 • Fax: +91 80 28367881  
Mobile: +91 9108220086 • Email: admin@mrsrack.com



# Innovations Customized

**MRS**<sup>®</sup>  
**MODULAR**  
RACK SYSTEMS PVT LTD

**WALL MOUNT  
RACKS**

**SS  
SERIES**



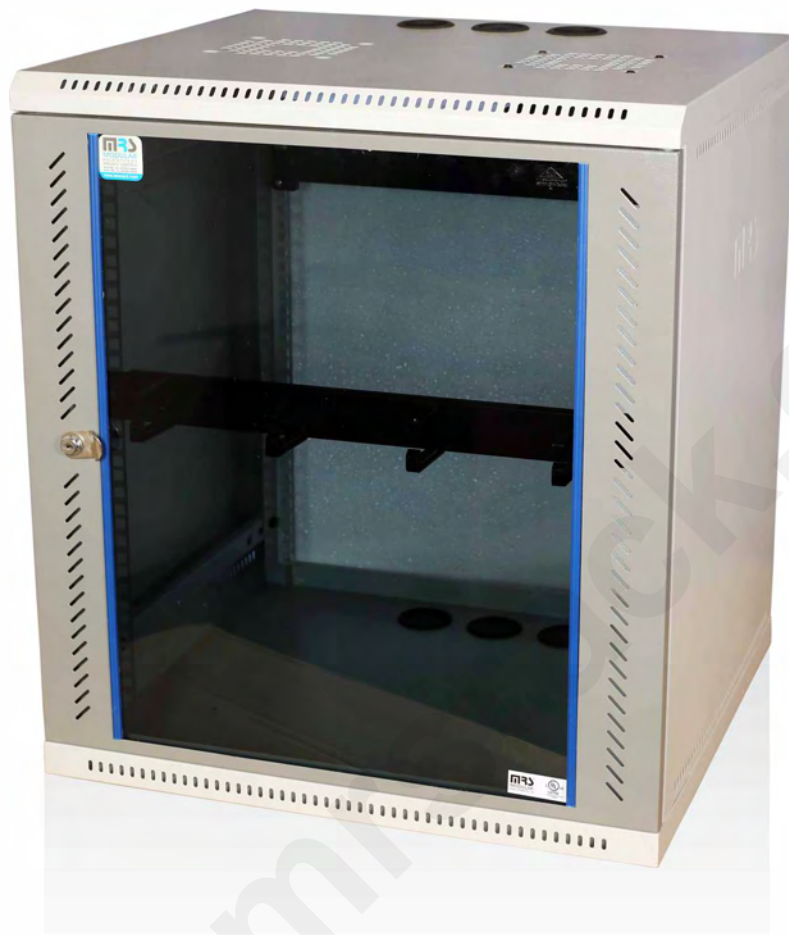

**MRS** offers a versatile range of single section wall mount racks to suit small secured network requirements.

Wall mount racks are the ideal solution where the floor space is a limitation, typical networking equipment like rotors, switches, patch panels, etc. are well accommodated in the rack.

**MRS** single section wall mount racks are fabricated out of C.R.C.A Steel Sheet CNC programmed, punched, bent, welded and powder coated with the highest quality under confirming Industrial, ISO 9001-2015 and 14001-2015 Standards. Manufacturing and quality management systems to ensure the highest quality product.

**MRS** single section wall mount racks are welded frame integrated with side panel / removable side panel, vented top cover with 2 fans and cable entry provision, bottom cover with ventilation and cable entry provision

associated with front toughened glass door along with lock and key and provision to mount on the wall.

**MRS** single section wall mount racks are available from 4 U to 15 U variants with 400, 500, and 600mm deep configuration.

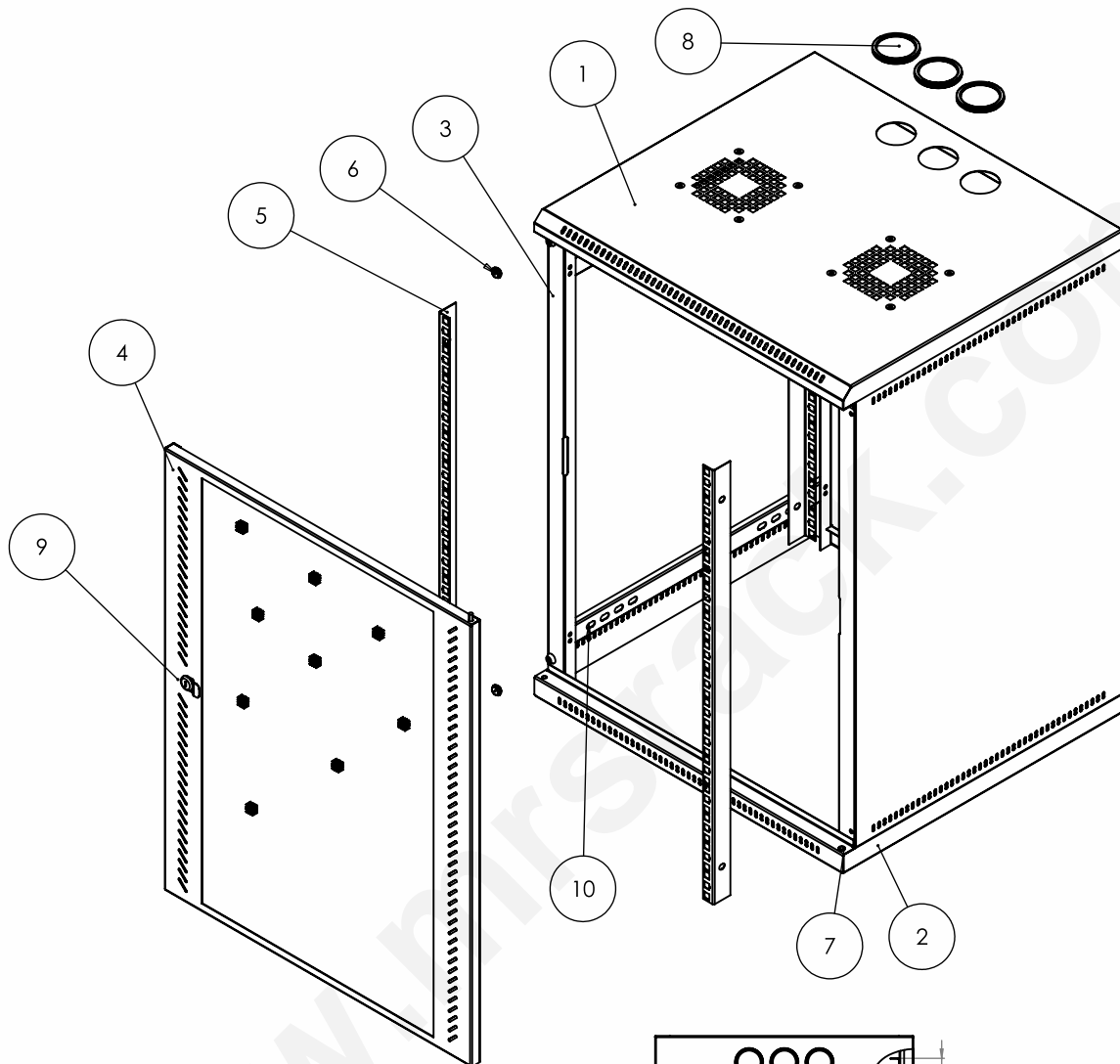

- 1 Top panel – Vented & provision for fan
- 2 Bottom panel - Vented
- 3 Side panel - Vented
- 4 Glass Door
- 5 L - Angle
- 6 Rubber Bumpons
- 7 Bushes (Nylon)
- 8 Rubber Grommet
- 9 Wall Mount Lock
- 10 C Channel

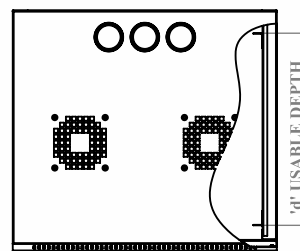

TOP VIEW

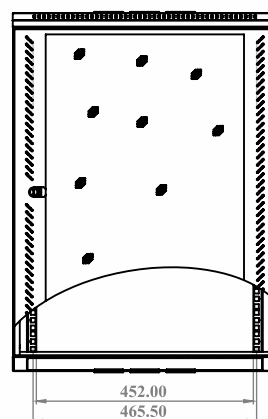

FRONT VIEW

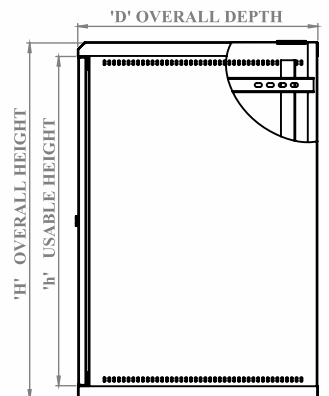

SIDE VIEW-RHS

# Product Features

- ◆ Conforms to DIN 41494 OR equivalent ISO Standard.
- ◆ Adjustable 4 nos. 19" angles with punched 10mm square holes and universal 12.7mm. 15.875. Alternating holes format offers for better mounting flexibility and maximizes usable mounting space.
- ◆ Depth adjustable mounting slots.
- ◆ Precision engineering capabilities and best efficient software configuration product technology provide the best product quality and fastest delivery in the industry.
- ◆ Top and bottom Panel with ventilation and cable entry facility.
- ◆ Provision to mount the cooling fans on the top panel.
- ◆ Powder coated finish with 7 Tank pretreatment process meeting ASTM standards.
- ◆ 100% assured compatibility with all equipment conforming to DIN 41494 (General industrial standard for equipment).

## Optional Accessories:

Grounding & Bonding Kit, Power Distribution Box, Instrument Cooling Fans, Cable Manager (Loop / Channel) Cantilever Shelves 250mm.

## ▶ Technical Data

BASIC FRAME	C.R.C.A Steel Sheet
CONSTRUCTION	Welded
SIDE PANELS	Integrated with top and bottom covers or (Removable type-on-request)
TOP AND BOTTOM PANEL	Vented with fan and cable entry provision
FRONT DOOR	Lockable toughened glass door with ventilation
STANDARD MOUNTING	DIN 41494 10mm. square slot
STANDARD FINISH	Powder Coating
STANDARD COLOR	Dark Grey and Light Grey or Black
STATIC LOAD	40 Kgs

## ▶ Product Codes and Dimensions

PART CODE	Total Height in MM (H)	Usable Height in U (H)	Total Width in MM (W)	Usable Width in Inches (W)	Total Depth in MM (D)	Usable Depth in MM (D)
<b>MRS-SS-5540-15U</b>	747	15U	550	19"	400	350

1U = 44.45 mm / 1.75 Inch

### Note:

1. Other models can be manufactured on request.
2. It is recommended to distribute the load along with "U" space in the rack.
3. All dimensions are in mm.



## MODULAR RACK SYSTEMS PVT. LTD.

No. 189 & 190, Nadikerappa Industrial Estate, Hegganahalli, Vishwaneedam Post,  
Bangalore-560 091 INDIA • Tel: +91 80 28365042 • Fax: +91 80 28367881  
Mobile: +91 9108220086 • Email: admin@mrsrack.com





# Innovations Customized

**MRS**<sup>®</sup>  
**MODULAR**  
RACK SYSTEMS PVT LTD

**WALL MOUNT  
RACKS**

**SS  
SERIES**





CERTIFIED

**MRS** offers a versatile range of single section wall mount racks to suit small secured network requirements.

Wall mount racks are the ideal solution where the floor space is a limitation, typical networking equipment like rotors, switches, patch panels, etc. are well accommodated in the rack.

**MRS** single section wall mount racks are fabricated out of C.R.C.A Steel Sheet CNC programmed, punched, bent, welded and powder coated with the highest quality under confirming Industrial, ISO 9001-2015 and 14001-2015 Standards. Manufacturing and quality management systems to ensure the highest quality product.

**MRS** single section wall mount racks are welded frame integrated with side panel / removable side panel, vented top cover with 2 fans and cable entry provision, bottom cover with ventilation and cable entry provision

associated with front toughened glass door along with lock and key and provision to mount on the wall.

**MRS** single section wall mount racks are available from 4 U to 15 U variants with 400, 500, and 600mm deep configuration.

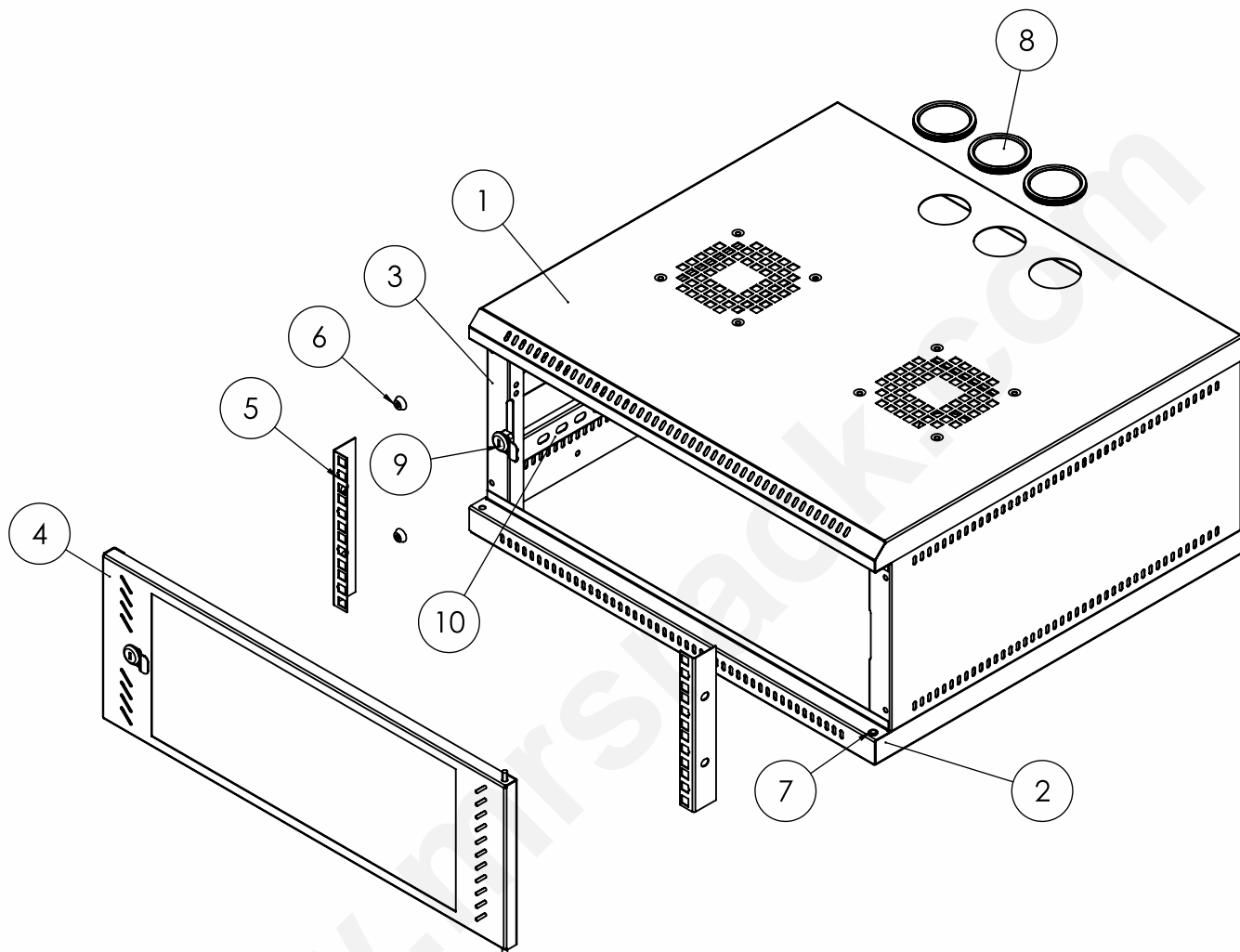

- 1 Top panel – Vented & provision for fan
- 2 Bottom panel - Vented
- 3 Side panel - Vented
- 4 Glass Door
- 5 L - Angle
- 6 Rubber Bumpons
- 7 Bushes (Nylon)
- 8 Rubber Grommet
- 9 Wall Mount Lock
- 10 C Channel

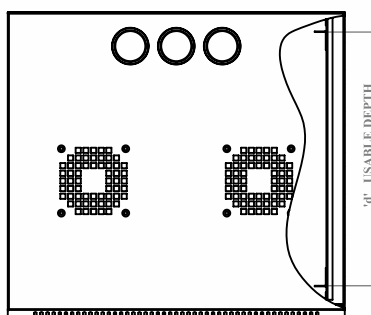

TOP VIEW

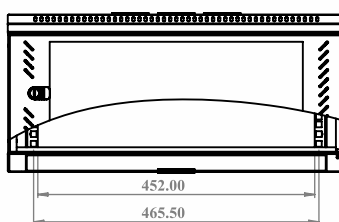

FRONT VIEW

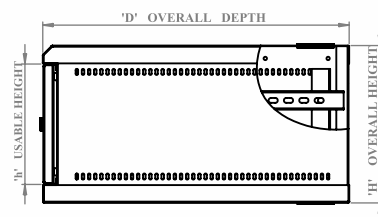

SIDE VIEW - RHS

# Product Features

- ◆ Conforms to DIN 41494 OR equivalent ISO Standard.
- ◆ Adjustable 4 nos. 19" angles with punched 10mm square holes and universal 12.7mm. 15.875. Alternating holes format offers for better mounting flexibility and maximizes usable mounting space.
- ◆ Depth adjustable mounting slots.
- ◆ Precision engineering capabilities and best efficient software configuration product technology provide the best product quality and fastest delivery in the industry.
- ◆ Top and bottom Panel with ventilation and cable entry facility.
- ◆ Provision to mount the cooling fans on the top panel.
- ◆ Powder coated finish with 7 Tank pretreatment process meeting ASTM standards.
- ◆ 100% assured compatibility with all equipment conforming to DIN 41494 (General industrial standard for equipment).

## Optional Accessories:

Grounding & Bonding Kit, Power Distribution Box, Instrument Cooling Fans, Cable Manager (Loop / Channel) Cantilever Shelves 250mm.

## ▶ Technical Data

BASIC FRAME	C.R.C.A Steel Sheet
CONSTRUCTION	Welded
SIDE PANELS	Integrated with top and bottom covers or (Removable type-on-request)
TOP AND BOTTOM PANEL	Vented with fan and cable entry provision
FRONT DOOR	Lockable toughened glass door with ventilation
STANDARD MOUNTING	DIN 41494 10mm. square slot
STANDARD FINISH	Powder Coating
STANDARD COLOR	Dark Grey and Light Grey or Black
STATIC LOAD	40 Kgs

## ▶ Product Codes and Dimensions

PART CODE	Total Height in MM (H)	Usable Height in U (H)	Total Width in MM (W)	Usable Width in Inches (W)	Total Depth in MM (D)	Usable Depth in MM (D)
<b>MRS-SS-5545-04U</b>	256	04U	550	19"	450	400

1U = 44.45 mm / 1.75 Inch

### Note:

1. Other models can be manufactured on request.
2. It is recommended to distribute the load along with "U" space in the rack.
3. All dimensions are in mm.



## MODULAR RACK SYSTEMS PVT. LTD.

No. 189 & 190, Nadikerappa Industrial Estate, Hegganahalli, Vishwaneedam Post,  
Bangalore-560 091 INDIA • Tel: +91 80 28365042 • Fax: +91 80 28367881  
Mobile: +91 9108220086 • Email: admin@mrsrack.com



# Innovations Customized

**MRS**<sup>®</sup>  
**MODULAR**  
RACK SYSTEMS PVT LTD

**WALL MOUNT  
RACKS**

**SS  
SERIES**





**MRS** offers a versatile range of single section wall mount racks to suit small secured network requirements.

Wall mount racks are the ideal solution where the floor space is a limitation, typical networking equipment like rotors, switches, patch panels, etc. are well accommodated in the rack.

**MRS** single section wall mount racks are fabricated out of C.R.C.A Steel Sheet CNC programmed, punched, bent, welded and powder coated with the highest quality under confirming Industrial, ISO 9001-2015 and 14001-2015 Standards. Manufacturing and quality management systems to ensure the highest quality product.

**MRS** single section wall mount racks are welded frame integrated with side panel / removable side panel, vented top cover with 2 fans and cable entry provision, bottom cover with ventilation and cable entry provision

associated with front toughened glass door along with lock and key and provision to mount on the wall.

**MRS** single section wall mount racks are available from 4 U to 15 U variants with 400, 500, and 600mm deep configuration.

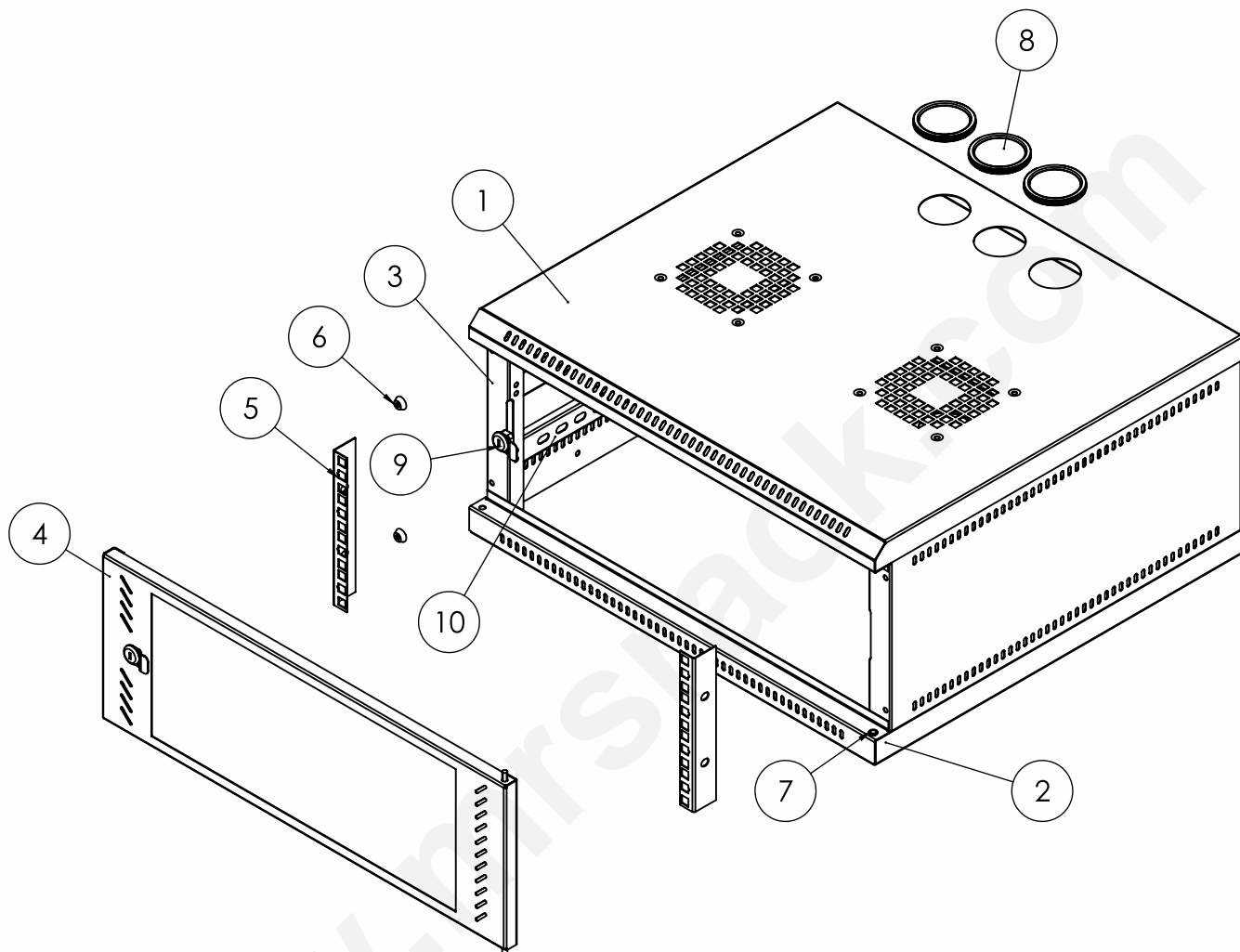

- 1 Top panel – Vented & provision for fan
- 2 Bottom panel - Vented
- 3 Side panel - Vented
- 4 Glass Door
- 5 L - Angle
- 6 Rubber Bumpons
- 7 Bushes (Nylon)
- 8 Rubber Grommet
- 9 Wall Mount Lock
- 10 C Channel

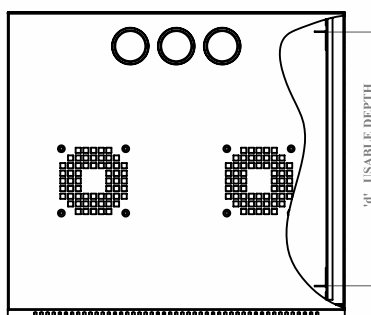

TOP VIEW

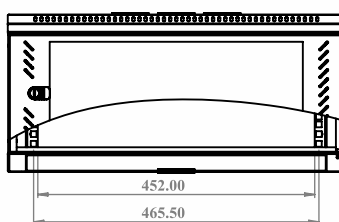

FRONT VIEW

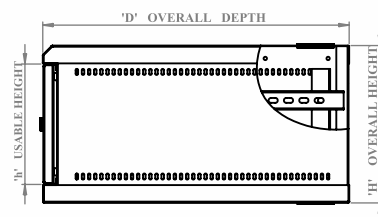

SIDE VIEW - RHS

# Product Features

- ◆ Conforms to DIN 41494 OR equivalent ISO Standard.
- ◆ Adjustable 4 nos. 19" angles with punched 10mm square holes and universal 12.7mm. 15.875. Alternating holes format offers for better mounting flexibility and maximizes usable mounting space.
- ◆ Depth adjustable mounting slots.
- ◆ Precision engineering capabilities and best efficient software configuration product technology provide the best product quality and fastest delivery in the industry.
- ◆ Top and bottom Panel with ventilation and cable entry facility.
- ◆ Provision to mount the cooling fans on the top panel.
- ◆ Powder coated finish with 7 Tank pretreatment process meeting ASTM standards.
- ◆ 100% assured compatibility with all equipment conforming to DIN 41494 (General industrial standard for equipment).

## Optional Accessories:

Grounding & Bonding Kit, Power Distribution Box, Instrument Cooling Fans, Cable Manager (Loop / Channel) Cantilever Shelves 250mm.

## ▶ Technical Data

BASIC FRAME	C.R.C.A Steel Sheet
CONSTRUCTION	Welded
SIDE PANELS	Integrated with top and bottom covers or (Removable type-on-request)
TOP AND BOTTOM PANEL	Vented with fan and cable entry provision
FRONT DOOR	Lockable toughened glass door with ventilation
STANDARD MOUNTING	DIN 41494 10mm. square slot
STANDARD FINISH	Powder Coating
STANDARD COLOR	Dark Grey and Light Grey or Black
STATIC LOAD	40 Kgs

## ▶ Product Codes and Dimensions

PART CODE	Total Height in MM (H)	Usable Height in U (H)	Total Width in MM (W)	Usable Width in Inches (W)	Total Depth in MM (D)	Usable Depth in MM (D)
<b>MRS-SS-5545-06U</b>	347	06U	550	19"	450	400

1U = 44.45 mm / 1.75 Inch

### Note:

1. Other models can be manufactured on request.
2. It is recommended to distribute the load along with "U" space in the rack.
3. All dimensions are in mm.



## MODULAR RACK SYSTEMS PVT. LTD.

No. 189 & 190, Nadikerappa Industrial Estate, Hegganahalli, Vishwaneedam Post,  
Bangalore-560 091 INDIA • Tel: +91 80 28365042 • Fax: +91 80 28367881  
Mobile: +91 9108220086 • Email: admin@mrsrack.com





# Innovations Customized

**MRS**<sup>®</sup>  
**MODULAR**  
RACK SYSTEMS PVT LTD

**WALL MOUNT  
RACKS**

**SS  
SERIES**





**MRS** offers a versatile range of single section wall mount racks to suit small secured network requirements.

Wall mount racks are the ideal solution where the floor space is a limitation, typical networking equipment like rotors, switches, patch panels, etc. are well accommodated in the rack.

**MRS** single section wall mount racks are fabricated out of C.R.C.A Steel Sheet CNC programmed, punched, bent, welded and powder coated with the highest quality under confirming Industrial, ISO 9001-2015 and 14001-2015 Standards. Manufacturing and quality management systems to ensure the highest quality product.

**MRS** single section wall mount racks are welded frame integrated with side panel / removable side panel, vented top cover with 2 fans and cable entry provision, bottom cover with ventilation and cable entry provision

associated with front toughened glass door along with lock and key and provision to mount on the wall.

**MRS** single section wall mount racks are available from 4 U to 15 U variants with 400, 500, and 600mm deep configuration.

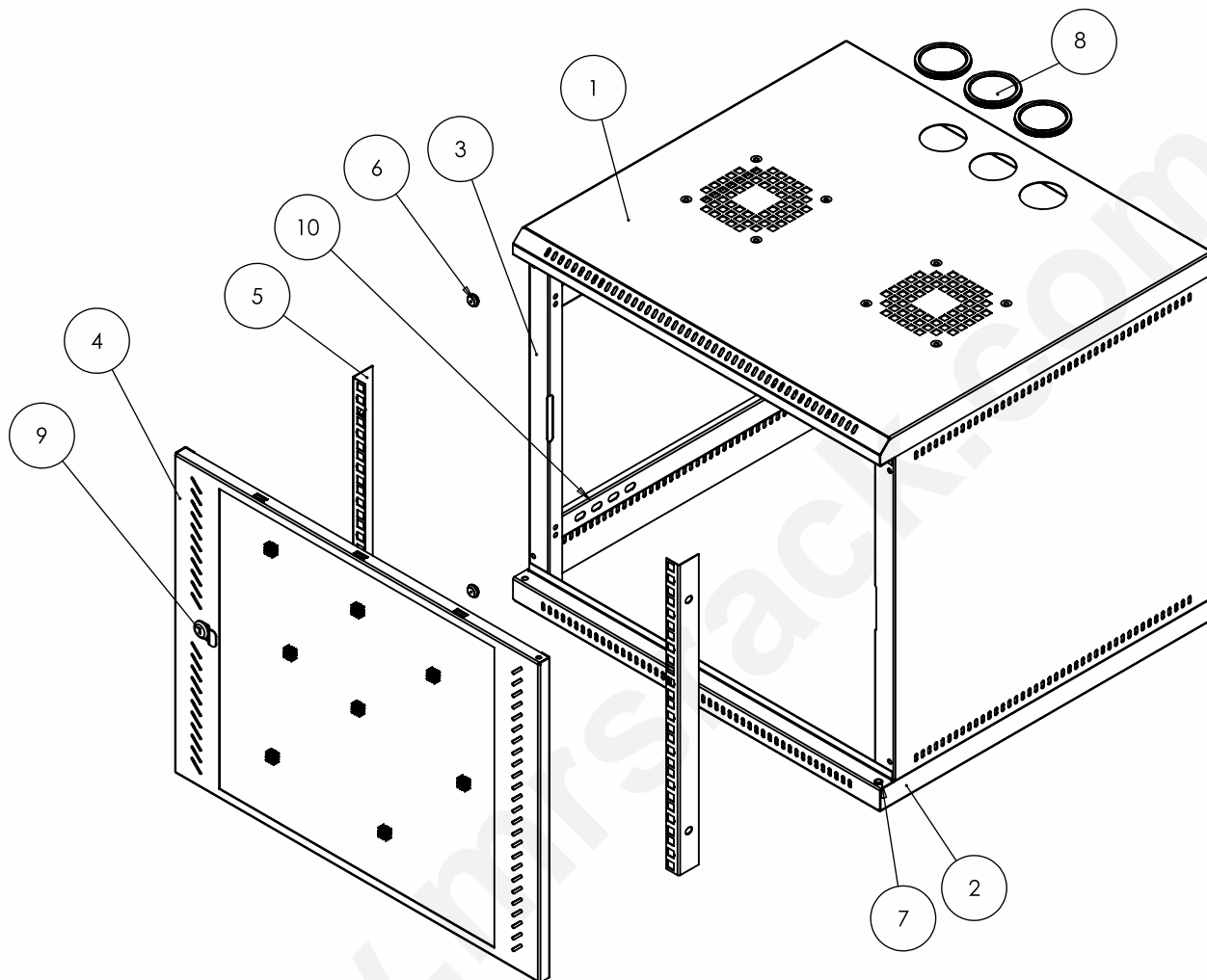

- 1 Top panel – Vented & provision for fan
- 2 Bottom panel - Vented
- 3 Side panel - Vented
- 4 Glass Door
- 5 L - Angle
- 6 Rubber Bumpons
- 7 Bushes (Nylon)
- 8 Rubber Grommet
- 9 Wall Mount Lock
- 10 C Channel

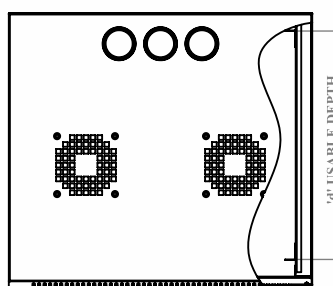

TOP VIEW

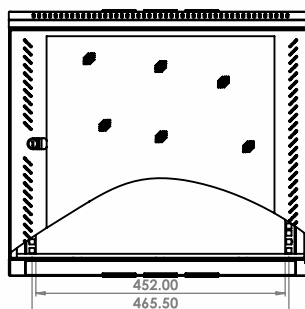

FRONT VIEW

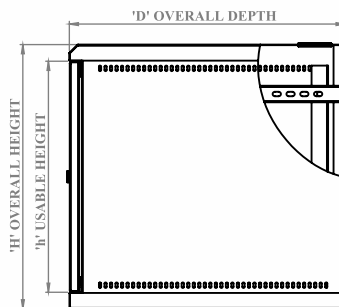

SIDE VIEW-RHS

# Product Features

- ◆ Conforms to DIN 41494 OR equivalent ISO Standard.
- ◆ Adjustable 4 nos. 19" angles with punched 10mm square holes and universal 12.7mm. 15.875. Alternating holes format offers for better mounting flexibility and maximizes usable mounting space.
- ◆ Depth adjustable mounting slots.
- ◆ Precision engineering capabilities and best efficient software configuration product technology provide the best product quality and fastest delivery in the industry.
- ◆ Top and bottom Panel with ventilation and cable entry facility.
- ◆ Provision to mount the cooling fans on the top panel.
- ◆ Powder coated finish with 7 Tank pretreatment process meeting ASTM standards.
- ◆ 100% assured compatibility with all equipment conforming to DIN 41494 (General industrial standard for equipment).

## Optional Accessories:

Grounding & Bonding Kit, Power Distribution Box, Instrument Cooling Fans, Cable Manager (Loop / Channel) Cantilever Shelves 250mm.

## ▶ Technical Data

BASIC FRAME	C.R.C.A Steel Sheet
CONSTRUCTION	Welded
SIDE PANELS	Integrated with top and bottom covers or (Removable type-on-request)
TOP AND BOTTOM PANEL	Vented with fan and cable entry provision
FRONT DOOR	Lockable toughened glass door with ventilation
STANDARD MOUNTING	DIN 41494 10mm. square slot
STANDARD FINISH	Powder Coating
STANDARD COLOR	Dark Grey and Light Grey or Black
STATIC LOAD	40 Kgs

## ▶ Product Codes and Dimensions

PART CODE	Total Height in MM (H)	Usable Height in U (H)	Total Width in MM (W)	Usable Width in Inches (W)	Total Depth in MM (D)	Usable Depth in MM (D)
<b>MRS-SS-5545-09U</b>	480	09U	550	19"	450	400

1U = 44.45 mm / 1.75 Inch

### Note:

1. Other models can be manufactured on request.
2. It is recommended to distribute the load along with "U" space in the rack.
3. All dimensions are in mm.



## MODULAR RACK SYSTEMS PVT. LTD.

No. 189 & 190, Nadikerappa Industrial Estate, Hegganahalli, Vishwaneedam Post,  
Bangalore-560 091 INDIA • Tel: +91 80 28365042 • Fax: +91 80 28367881  
Mobile: +91 9108220086 • Email: admin@mrsrack.com



# Innovations Customized

**MRS**<sup>®</sup>  
**MODULAR**  
RACK SYSTEMS PVT LTD

**WALL MOUNT  
RACKS**

**SS  
SERIES**



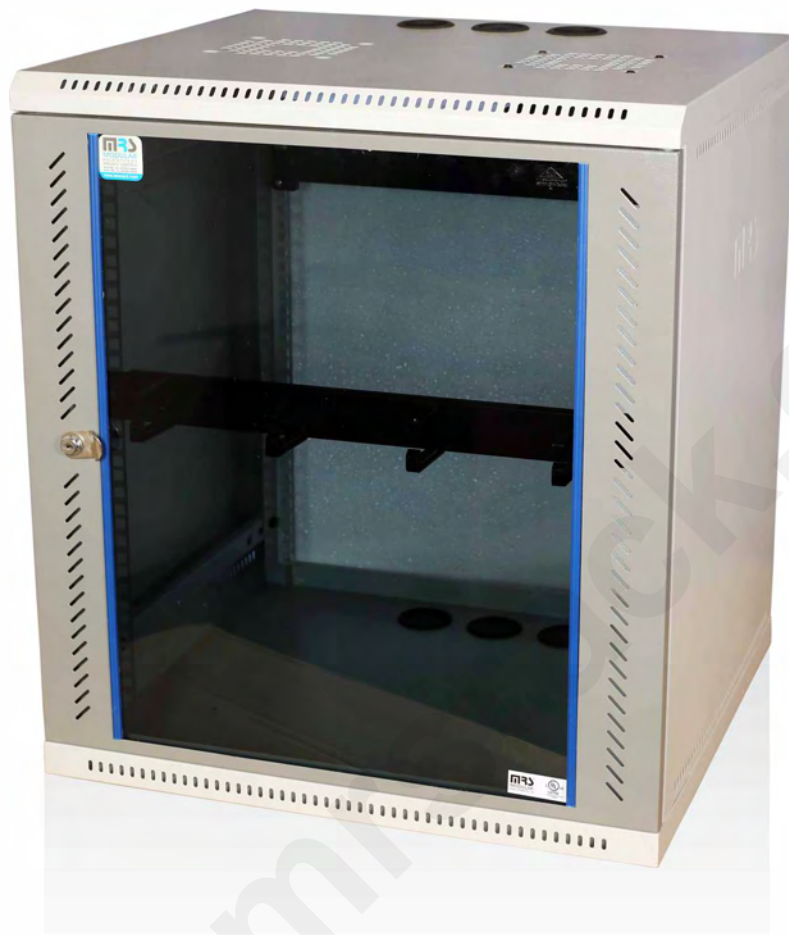

**MRS** offers a versatile range of single section wall mount racks to suit small secured network requirements.

Wall mount racks are the ideal solution where the floor space is a limitation, typical networking equipment like rotors, switches, patch panels, etc. are well accommodated in the rack.

**MRS** single section wall mount racks are fabricated out of C.R.C.A Steel Sheet CNC programmed, punched, bent, welded and powder coated with the highest quality under confirming Industrial, ISO 9001-2015 and 14001-2015 Standards. Manufacturing and quality management systems to ensure the highest quality product.

**MRS** single section wall mount racks are welded frame integrated with side panel / removable side panel, vented top cover with 2 fans and cable entry provision, bottom cover with ventilation and cable entry provision

associated with front toughened glass door along with lock and key and provision to mount on the wall.

**MRS** single section wall mount racks are available from 4 U to 15 U variants with 400, 500, and 600mm deep configuration.

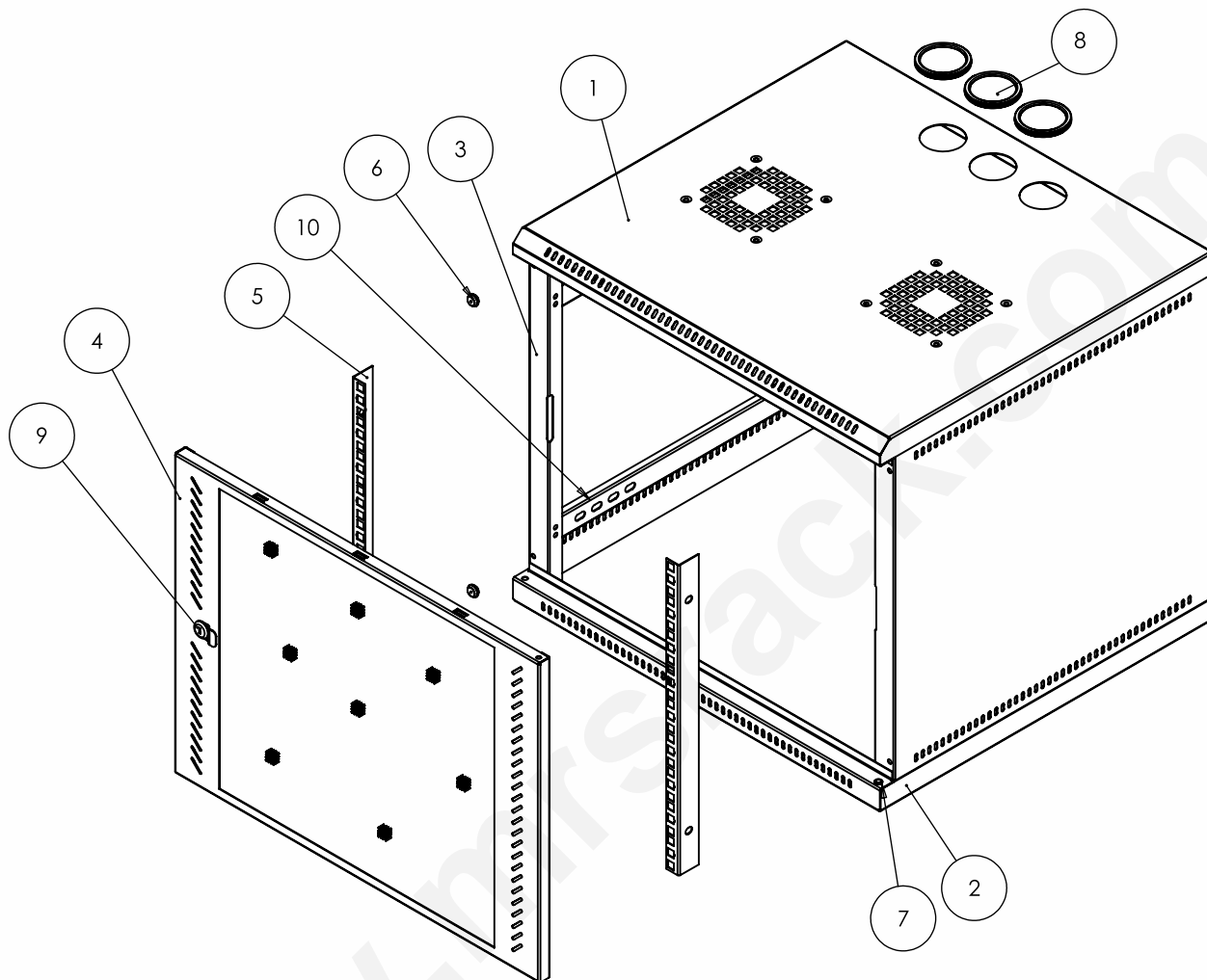

- 1 Top panel – Vented & provision for fan
- 2 Bottom panel - Vented
- 3 Side panel - Vented
- 4 Glass Door
- 5 L - Angle
- 6 Rubber Bumpons
- 7 Bushes (Nylon)
- 8 Rubber Grommet
- 9 Wall Mount Lock
- 10 C Channel

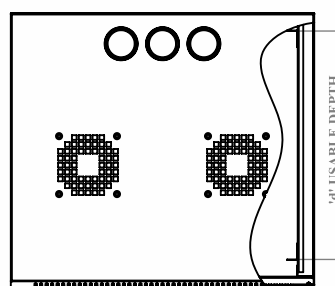

TOP VIEW

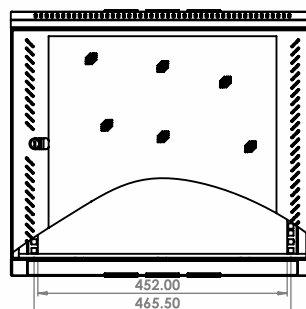

FRONT VIEW

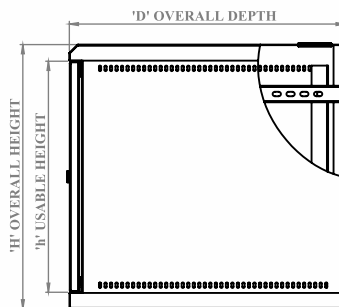

SIDE VIEW-RHS

# Product Features

- ◆ Conforms to DIN 41494 OR equivalent ISO Standard.
- ◆ Adjustable 4 nos. 19" angles with punched 10mm square holes and universal 12.7mm. 15.875. Alternating holes format offers for better mounting flexibility and maximizes usable mounting space.
- ◆ Depth adjustable mounting slots.
- ◆ Precision engineering capabilities and best efficient software configuration product technology provide the best product quality and fastest delivery in the industry.
- ◆ Top and bottom Panel with ventilation and cable entry facility.
- ◆ Provision to mount the cooling fans on the top panel.
- ◆ Powder coated finish with 7 Tank pretreatment process meeting ASTM standards.
- ◆ 100% assured compatibility with all equipment conforming to DIN 41494 (General industrial standard for equipment).

## Optional Accessories:

Grounding & Bonding Kit, Power Distribution Box, Instrument Cooling Fans, Cable Manager (Loop / Channel) Cantilever Shelves 250mm.

## ▶ Technical Data

BASIC FRAME	C.R.C.A Steel Sheet
CONSTRUCTION	Welded
SIDE PANELS	Integrated with top and bottom covers or (Removable type-on-request)
TOP AND BOTTOM PANEL	Vented with fan and cable entry provision
FRONT DOOR	Lockable toughened glass door with ventilation
STANDARD MOUNTING	DIN 41494 10mm. square slot
STANDARD FINISH	Powder Coating
STANDARD COLOR	Dark Grey and Light Grey or Black
STATIC LOAD	40 Kgs

## ▶ Product Codes and Dimensions

PART CODE	Total Height in MM (H)	Usable Height in U (H)	Total Width in MM (W)	Usable Width in Inches (W)	Total Depth in MM (D)	Usable Depth in MM (D)
MRS-SS-5545-12U	613	12U	550	19"	450	400

1U = 44.45 mm / 1.75 Inch

### Note:

1. Other models can be manufactured on request.
2. It is recommended to distribute the load along with "U" space in the rack.
3. All dimensions are in mm.



## MODULAR RACK SYSTEMS PVT. LTD.

No. 189 & 190, Nadikerappa Industrial Estate, Hegganahalli, Vishwaneedam Post,  
Bangalore-560 091 INDIA • Tel: +91 80 28365042 • Fax: +91 80 28367881  
Mobile: +91 9108220086 • Email: admin@mrsrack.com





# Innovations Customized

**MRS**<sup>®</sup>  
**MODULAR**  
RACK SYSTEMS PVT LTD

**WALL MOUNT  
RACKS**

**SS  
SERIES**





**MRS** offers a versatile range of single section wall mount racks to suit small secured network requirements.

Wall mount racks are the ideal solution where the floor space is a limitation, typical networking equipment like rotors, switches, patch panels, etc. are well accommodated in the rack.

**MRS** single section wall mount racks are fabricated out of C.R.C.A Steel Sheet CNC programmed, punched, bent, welded and powder coated with the highest quality under confirming Industrial, ISO 9001-2015 and 14001-2015 Standards. Manufacturing and quality management systems to ensure the highest quality product.

**MRS** single section wall mount racks are welded frame integrated with side panel / removable side panel, vented top cover with 2 fans and cable entry provision, bottom cover with ventilation and cable entry provision

associated with front toughened glass door along with lock and key and provision to mount on the wall.

**MRS** single section wall mount racks are available from 4 U to 15 U variants with 400, 500, and 600mm deep configuration.

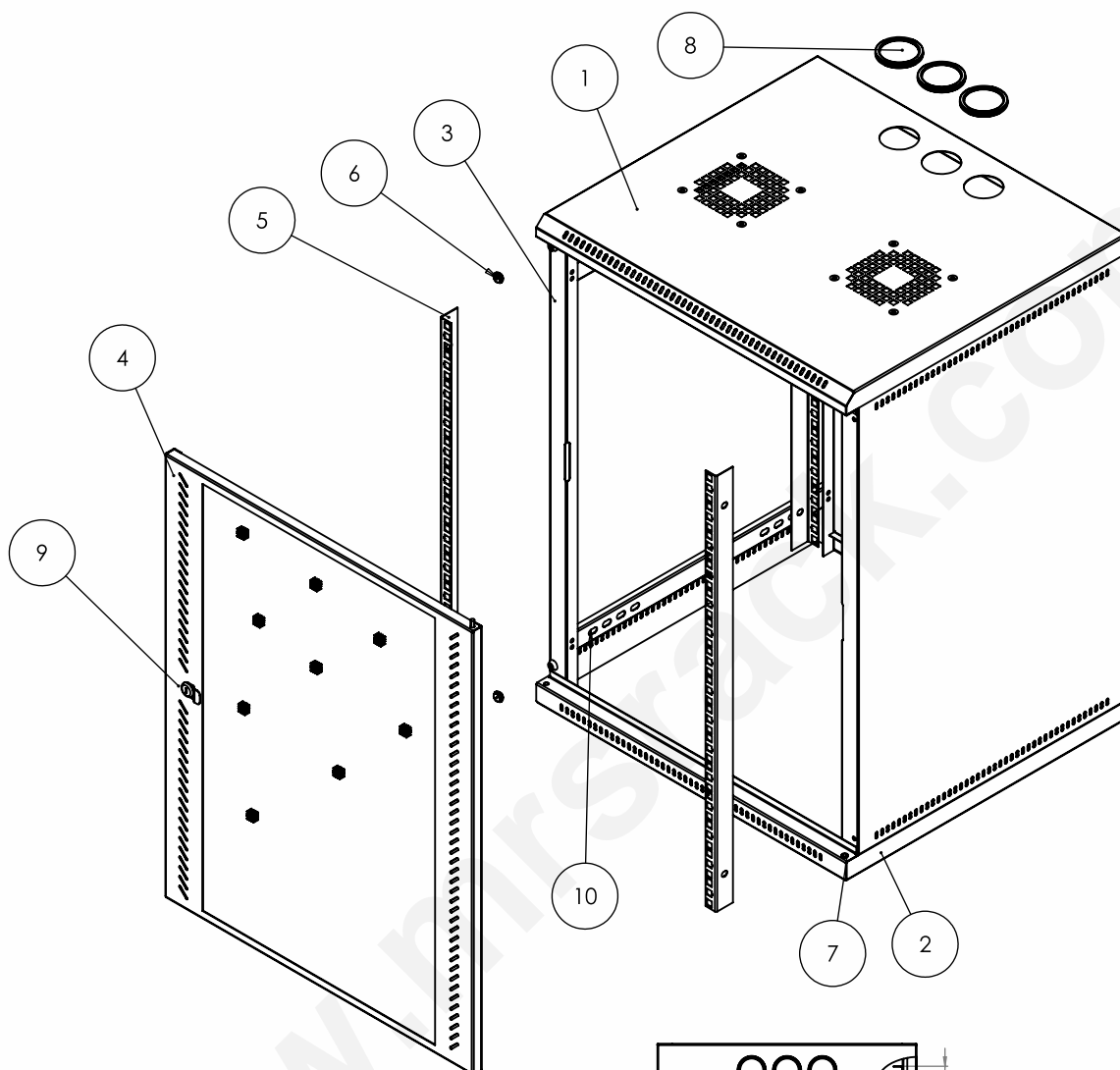

- 1 Top panel – Vented & provision for fan
- 2 Bottom panel - Vented
- 3 Side panel - Vented
- 4 Glass Door
- 5 L - Angle
- 6 Rubber Bumpons
- 7 Bushes (Nylon)
- 8 Rubber Grommet
- 9 Wall Mount Lock
- 10 C Channel

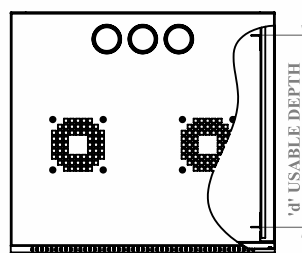

TOP VIEW

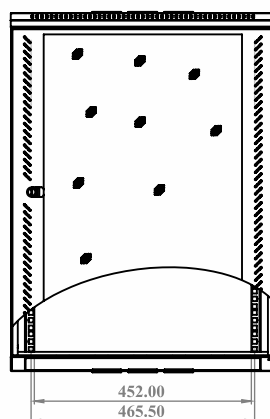

FRONT VIEW

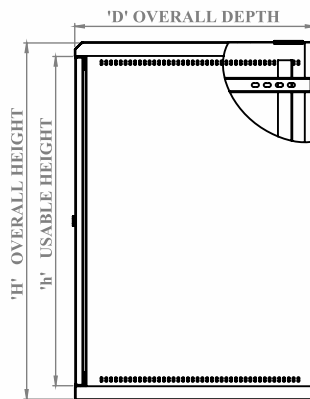

SIDE VIEW-RHS

# Product Features

- ◆ Conforms to DIN 41494 OR equivalent ISO Standard.
- ◆ Adjustable 4 nos. 19" angles with punched 10mm square holes and universal 12.7mm. 15.875. Alternating holes format offers for better mounting flexibility and maximizes usable mounting space.
- ◆ Depth adjustable mounting slots.
- ◆ Precision engineering capabilities and best efficient software configuration product technology provide the best product quality and fastest delivery in the industry.
- ◆ Top and bottom Panel with ventilation and cable entry facility.
- ◆ Provision to mount the cooling fans on the top panel.
- ◆ Powder coated finish with 7 Tank pretreatment process meeting ASTM standards.
- ◆ 100% assured compatibility with all equipment conforming to DIN 41494 (General industrial standard for equipment).

## Optional Accessories:

Grounding & Bonding Kit, Power Distribution Box, Instrument Cooling Fans, Cable Manager (Loop / Channel) Cantilever Shelves 250mm.

## ▶ Technical Data

BASIC FRAME	C.R.C.A Steel Sheet
CONSTRUCTION	Welded
SIDE PANELS	Integrated with top and bottom covers or (Removable type-on-request)
TOP AND BOTTOM PANEL	Vented with fan and cable entry provision
FRONT DOOR	Lockable toughened glass door with ventilation
STANDARD MOUNTING	DIN 41494 10mm. square slot
STANDARD FINISH	Powder Coating
STANDARD COLOR	Dark Grey and Light Grey or Black
STATIC LOAD	40 Kgs

## ▶ Product Codes and Dimensions

PART CODE	Total Height in MM (H)	Usable Height in U (H)	Total Width in MM (W)	Usable Width in Inches (W)	Total Depth in MM (D)	Usable Depth in MM (D)
<b>MRS-SS-5545-15U</b>	747	15U	550	19"	450	400

1U = 44.45 mm / 1.75 Inch

### Note:

1. Other models can be manufactured on request.
2. It is recommended to distribute the load along with "U" space in the rack.
3. All dimensions are in mm.



## MODULAR RACK SYSTEMS PVT. LTD.

No. 189 & 190, Nadikerappa Industrial Estate, Hegganahalli, Vishwaneedam Post,  
Bangalore-560 091 INDIA • Tel: +91 80 28365042 • Fax: +91 80 28367881  
Mobile: +91 9108220086 • Email: admin@mrsrack.com



# Innovations Customized

**MRS**<sup>®</sup>  
**MODULAR**  
RACK SYSTEMS PVT LTD

**WALL MOUNT  
RACKS**

**SS  
SERIES**





CERTIFIED

**MRS** offers a versatile range of single section wall mount racks to suit small secured network requirements.

Wall mount racks are the ideal solution where the floor space is a limitation, typical networking equipment like rotors, switches, patch panels, etc. are well accommodated in the rack.

**MRS** single section wall mount racks are fabricated out of C.R.C.A Steel Sheet CNC programmed, punched, bent, welded and powder coated with the highest quality under confirming Industrial, ISO 9001-2015 and 14001-2015 Standards. Manufacturing and quality management systems to ensure the highest quality product.

**MRS** single section wall mount racks are welded frame integrated with side panel / removable side panel, vented top cover with 2 fans and cable entry provision, bottom cover with ventilation and cable entry provision

associated with front toughened glass door along with lock and key and provision to mount on the wall.

**MRS** single section wall mount racks are available from 4 U to 15 U variants with 400, 500, and 600mm deep configuration.

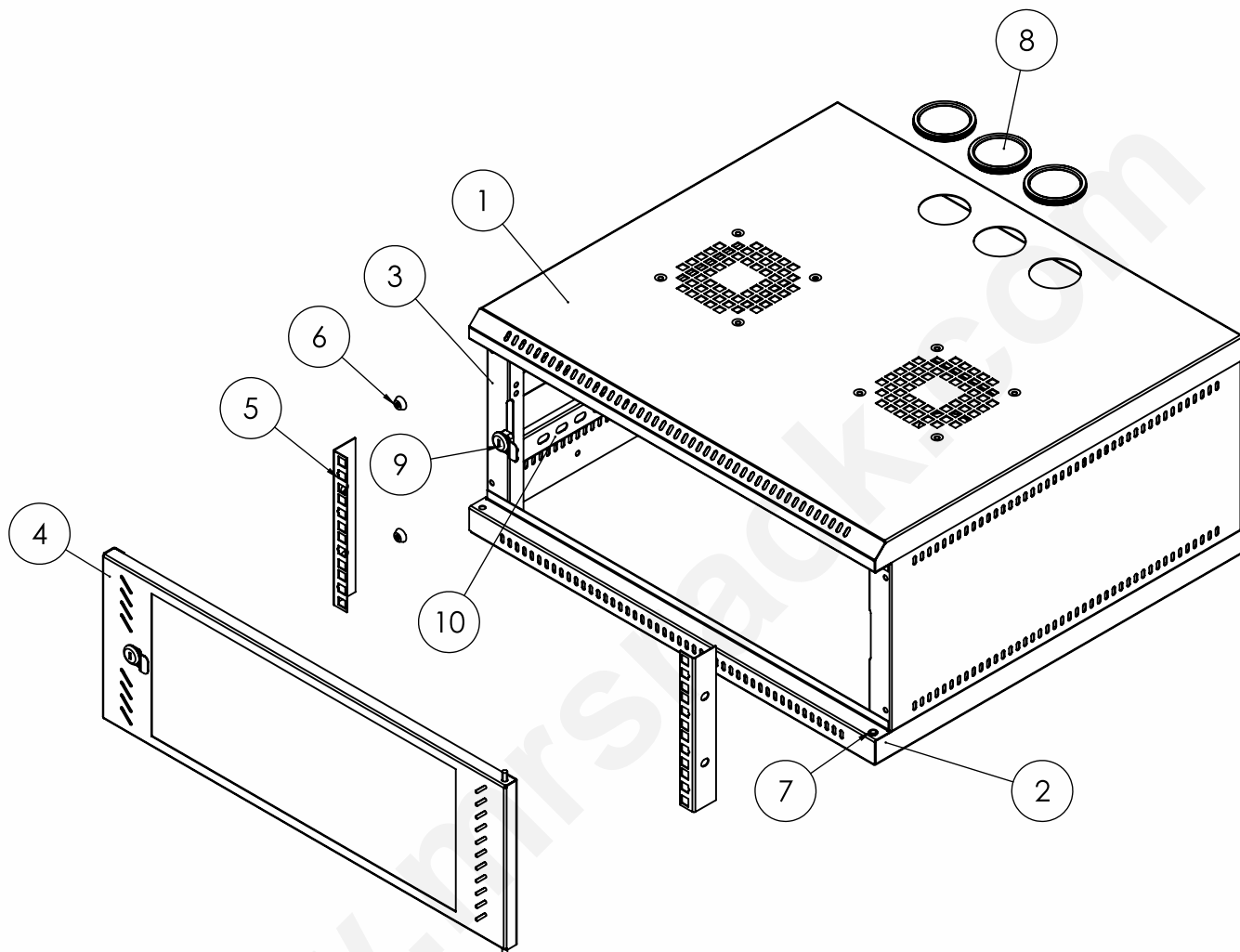

- 1 Top panel – Vented & provision for fan
- 2 Bottom panel - Vented
- 3 Side panel - Vented
- 4 Glass Door
- 5 L - Angle
- 6 Rubber Bumpons
- 7 Bushes (Nylon)
- 8 Rubber Grommet
- 9 Wall Mount Lock
- 10 C Channel

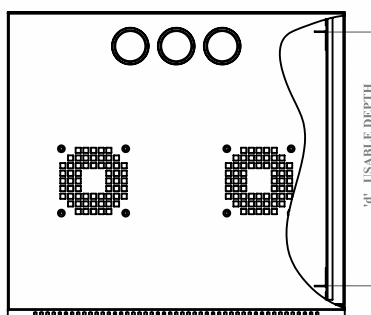

TOP VIEW

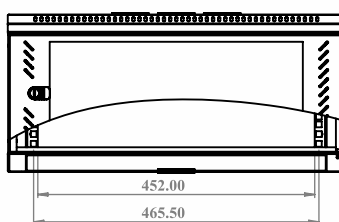

FRONT VIEW

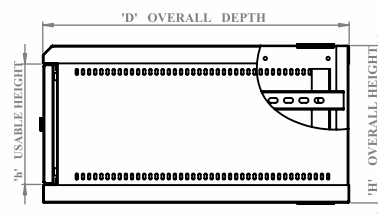

SIDE VIEW - RHS

# Product Features

- ◆ Conforms to DIN 41494 OR equivalent ISO Standard.
- ◆ Adjustable 4 nos. 19" angles with punched 10mm square holes and universal 12.7mm. 15.875. Alternating holes format offers for better mounting flexibility and maximizes usable mounting space.
- ◆ Depth adjustable mounting slots.
- ◆ Precision engineering capabilities and best efficient software configuration product technology provide the best product quality and fastest delivery in the industry.
- ◆ Top and bottom Panel with ventilation and cable entry facility.
- ◆ Provision to mount the cooling fans on the top panel.
- ◆ Powder coated finish with 7 Tank pretreatment process meeting ASTM standards.
- ◆ 100% assured compatibility with all equipment conforming to DIN 41494 (General industrial standard for equipment).

## Optional Accessories:

Grounding & Bonding Kit, Power Distribution Box, Instrument Cooling Fans, Cable Manager (Loop / Channel) Cantilever Shelves 250mm.

## ▶ Technical Data

BASIC FRAME	C.R.C.A Steel Sheet
CONSTRUCTION	Welded
SIDE PANELS	Integrated with top and bottom covers or (Removable type-on-request)
TOP AND BOTTOM PANEL	Vented with fan and cable entry provision
FRONT DOOR	Lockable toughened glass door with ventilation
STANDARD MOUNTING	DIN 41494 10mm. square slot
STANDARD FINISH	Powder Coating
STANDARD COLOR	Dark Grey and Light Grey or Black
STATIC LOAD	40 Kgs

## ▶ Product Codes and Dimensions

PART CODE	Total Height in MM (H)	Usable Height in U (H)	Total Width in MM (W)	Usable Width in Inches (W)	Total Depth in MM (D)	Usable Depth in MM (D)
<b>MRS-SS-5550-04U</b>	256	04U	550	19"	500	450

1U = 44.45 mm / 1.75 Inch

### Note:

1. Other models can be manufactured on request.
2. It is recommended to distribute the load along with "U" space in the rack.
3. All dimensions are in mm.



## MODULAR RACK SYSTEMS PVT. LTD.

No. 189 & 190, Nadikerappa Industrial Estate, Hegganahalli, Vishwaneedam Post,  
Bangalore-560 091 INDIA • Tel: +91 80 28365042 • Fax: +91 80 28367881  
Mobile: +91 9108220086 • Email: admin@mrsrack.com





# Innovations Customized

**MRS**<sup>®</sup>  
**MODULAR**  
RACK SYSTEMS PVT LTD

**WALL MOUNT  
RACKS**

**SS  
SERIES**



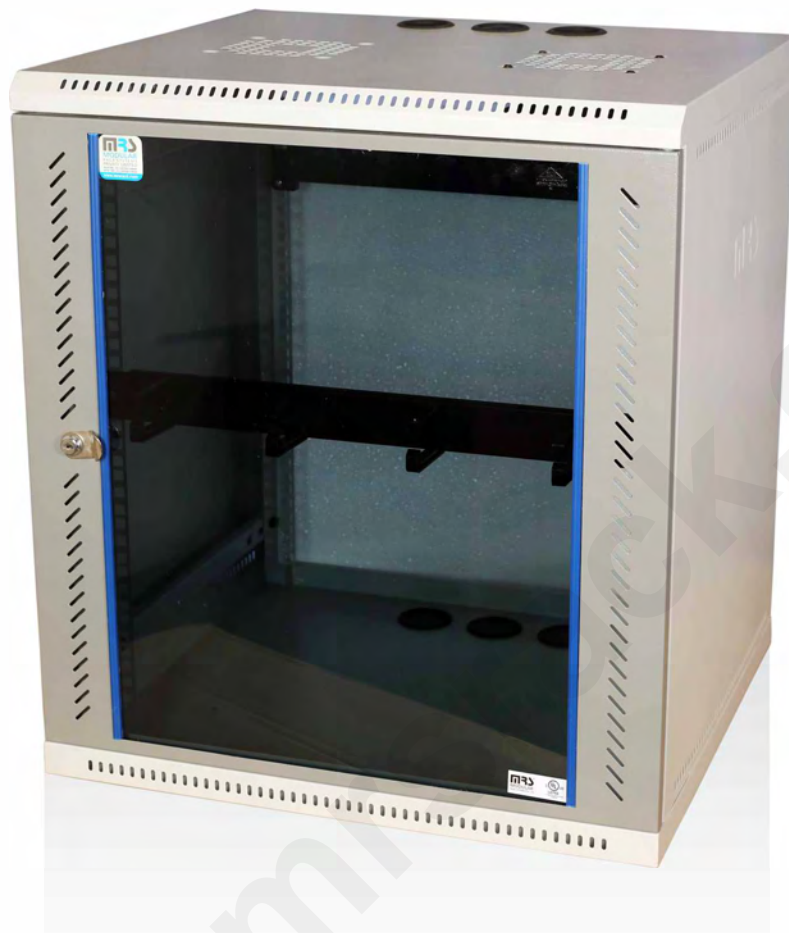

**MRS** offers a versatile range of single section wall mount racks to suit small secured network requirements.

Wall mount racks are the ideal solution where the floor space is a limitation, typical networking equipment like rotors, switches, patch panels, etc. are well accommodated in the rack.

**MRS** single section wall mount racks are fabricated out of C.R.C.A Steel Sheet CNC programmed, punched, bent, welded and powder coated with the highest quality under confirming Industrial, ISO 9001-2015 and 14001-2015 Standards. Manufacturing and quality management systems to ensure the highest quality product.

**MRS** single section wall mount racks are welded frame integrated with side panel / removable side panel, vented top cover with 2 fans and cable entry provision, bottom cover with ventilation and cable entry provision

associated with front toughened glass door along with lock and key and provision to mount on the wall.

**MRS** single section wall mount racks are available from 4 U to 15 U variants with 400, 500, and 600mm deep configuration.

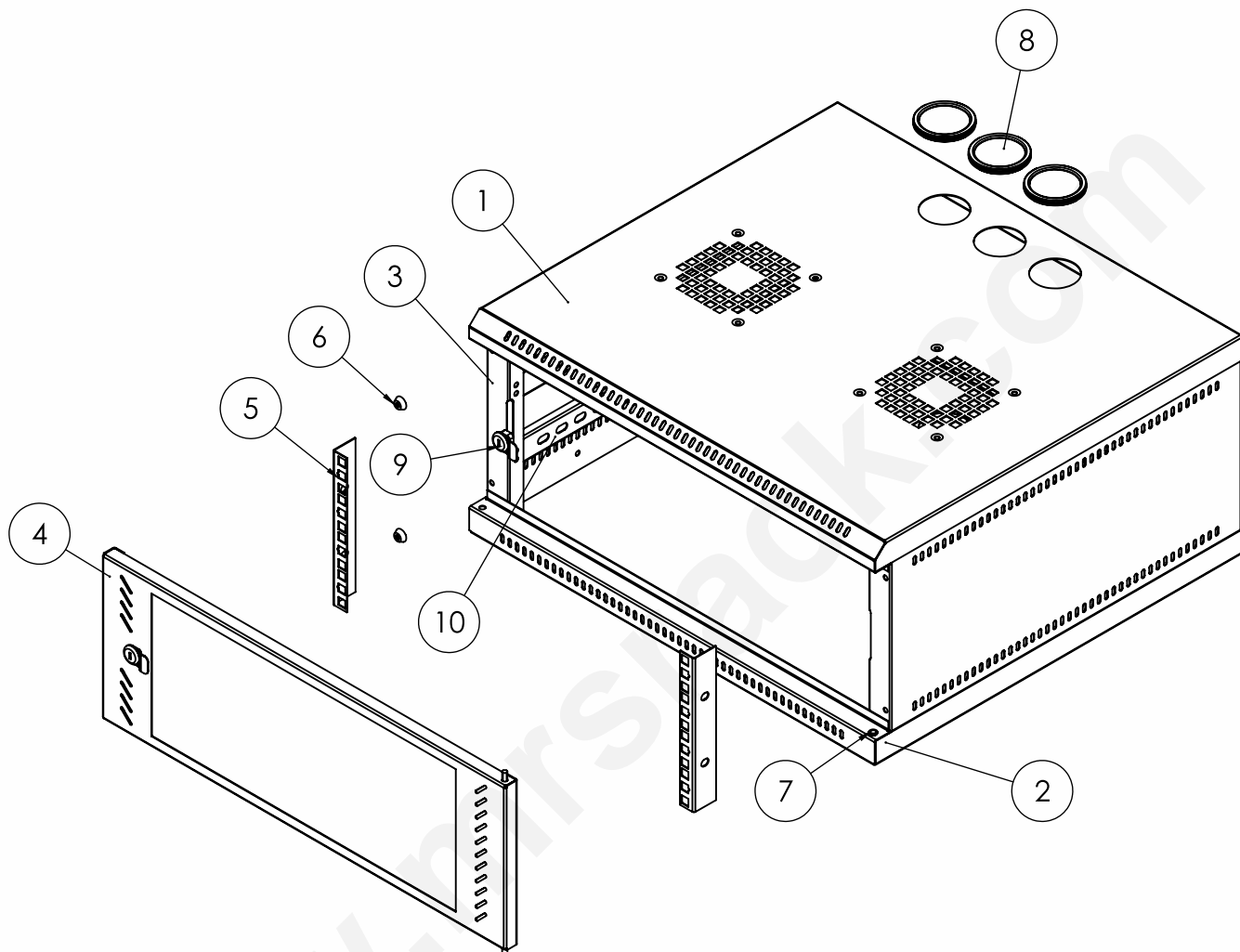

- 1 Top panel – Vented & provision for fan
- 2 Bottom panel - Vented
- 3 Side panel - Vented
- 4 Glass Door
- 5 L - Angle
- 6 Rubber Bumpons
- 7 Bushes (Nylon)
- 8 Rubber Grommet
- 9 Wall Mount Lock
- 10 C Channel

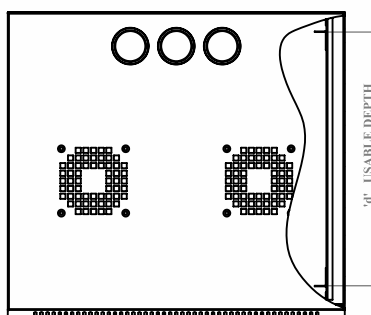

TOP VIEW

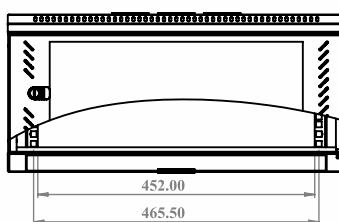

FRONT VIEW

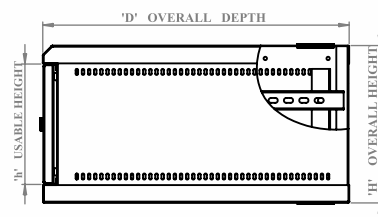

SIDE VIEW - RHS

# Product Features

- ◆ Conforms to DIN 41494 OR equivalent ISO Standard.
- ◆ Adjustable 4 nos. 19" angles with punched 10mm square holes and universal 12.7mm. 15.875. Alternating holes format offers for better mounting flexibility and maximizes usable mounting space.
- ◆ Depth adjustable mounting slots.
- ◆ Precision engineering capabilities and best efficient software configuration product technology provide the best product quality and fastest delivery in the industry.
- ◆ Top and bottom Panel with ventilation and cable entry facility.
- ◆ Provision to mount the cooling fans on the top panel.
- ◆ Powder coated finish with 7 Tank pretreatment process meeting ASTM standards.
- ◆ 100% assured compatibility with all equipment conforming to DIN 41494 (General industrial standard for equipment).

## Optional Accessories:

Grounding & Bonding Kit, Power Distribution Box, Instrument Cooling Fans, Cable Manager (Loop / Channel) Cantilever Shelves 250mm.

## ▶ Technical Data

BASIC FRAME	C.R.C.A Steel Sheet
CONSTRUCTION	Welded
SIDE PANELS	Integrated with top and bottom covers or (Removable type-on-request)
TOP AND BOTTOM PANEL	Vented with fan and cable entry provision
FRONT DOOR	Lockable toughened glass door with ventilation
STANDARD MOUNTING	DIN 41494 10mm. square slot
STANDARD FINISH	Powder Coating
STANDARD COLOR	Dark Grey and Light Grey or Black
STATIC LOAD	40 Kgs

## ▶ Product Codes and Dimensions

PART CODE	Total Height in MM (H)	Usable Height in U (H)	Total Width in MM (W)	Usable Width in Inches (W)	Total Depth in MM (D)	Usable Depth in MM (D)
MRS-SS-5550-06U	347	06U	550	19"	500	450

1U = 44.45 mm / 1.75 Inch

### Note:

1. Other models can be manufactured on request.
2. It is recommended to distribute the load along with "U" space in the rack.
3. All dimensions are in mm.



## MODULAR RACK SYSTEMS PVT. LTD.

No. 189 & 190, Nadikerappa Industrial Estate, Hegganahalli, Vishwaneedam Post,  
Bangalore-560 091 INDIA • Tel: +91 80 28365042 • Fax: +91 80 28367881  
Mobile: +91 9108220086 • Email: admin@mrsrack.com



# Innovations Customized

**MRS**<sup>®</sup>  
**MODULAR**  
RACK SYSTEMS PVT LTD

**WALL MOUNT  
RACKS**

**SS  
SERIES**





**MRS** offers a versatile range of single section wall mount racks to suit small secured network requirements.

Wall mount racks are the ideal solution where the floor space is a limitation, typical networking equipment like rotors, switches, patch panels, etc. are well accommodated in the rack.

**MRS** single section wall mount racks are fabricated out of C.R.C.A Steel Sheet CNC programmed, punched, bent, welded and powder coated with the highest quality under confirming Industrial, ISO 9001-2015 and 14001-2015 Standards. Manufacturing and quality management systems to ensure the highest quality product.

**MRS** single section wall mount racks are welded frame integrated with side panel / removable side panel, vented top cover with 2 fans and cable entry provision, bottom cover with ventilation and cable entry provision

associated with front toughened glass door along with lock and key and provision to mount on the wall.

**MRS** single section wall mount racks are available from 4 U to 15 U variants with 400, 500, and 600mm deep configuration.

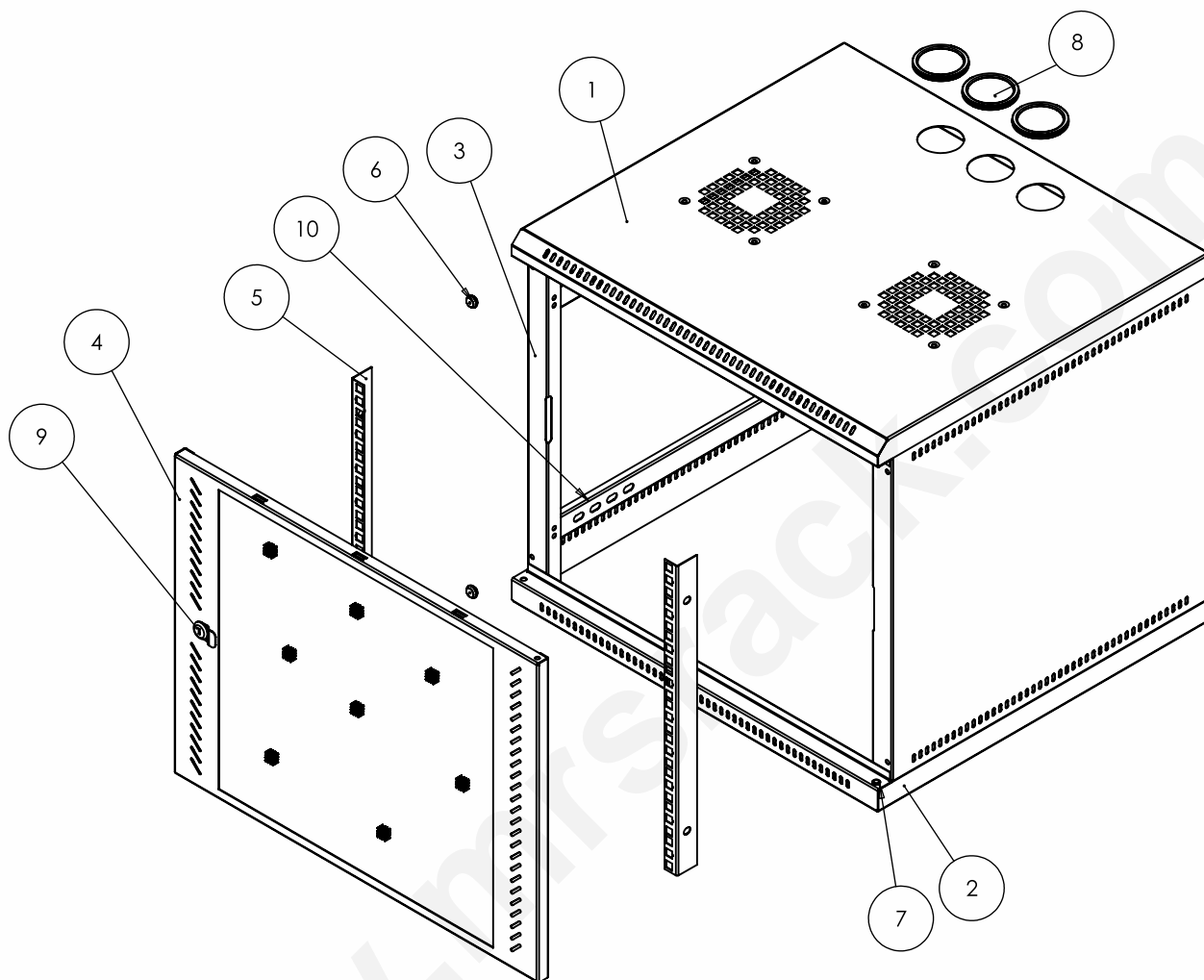

- 1 Top panel – Vented & provision for fan
- 2 Bottom panel - Vented
- 3 Side panel - Vented
- 4 Glass Door
- 5 L - Angle
- 6 Rubber Bumpons
- 7 Bushes (Nylon)
- 8 Rubber Grommet
- 9 Wall Mount Lock
- 10 C Channel

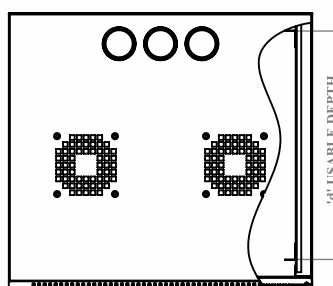

TOP VIEW

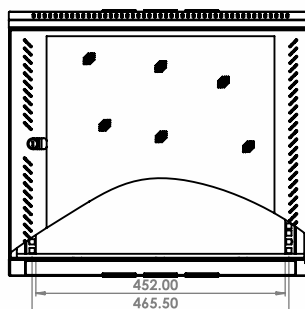

FRONT VIEW

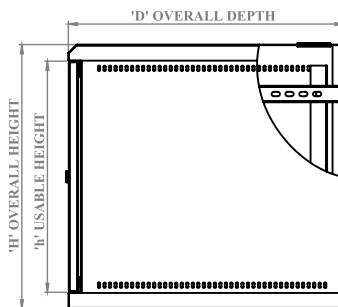

SIDE VIEW-RHS

# Product Features

- ◆ Conforms to DIN 41494 OR equivalent ISO Standard.
- ◆ Adjustable 4 nos. 19" angles with punched 10mm square holes and universal 12.7mm. 15.875. Alternating holes format offers for better mounting flexibility and maximizes usable mounting space.
- ◆ Depth adjustable mounting slots.
- ◆ Precision engineering capabilities and best efficient software configuration product technology provide the best product quality and fastest delivery in the industry.
- ◆ Top and bottom Panel with ventilation and cable entry facility.
- ◆ Provision to mount the cooling fans on the top panel.
- ◆ Powder coated finish with 7 Tank pretreatment process meeting ASTM standards.
- ◆ 100% assured compatibility with all equipment conforming to DIN 41494 (General industrial standard for equipment).

## Optional Accessories:

Grounding & Bonding Kit, Power Distribution Box, Instrument Cooling Fans, Cable Manager (Loop / Channel) Cantilever Shelves 250mm.

## ▶ Technical Data

BASIC FRAME	C.R.C.A Steel Sheet
CONSTRUCTION	Welded
SIDE PANELS	Integrated with top and bottom covers or (Removable type-on-request)
TOP AND BOTTOM PANEL	Vented with fan and cable entry provision
FRONT DOOR	Lockable toughened glass door with ventilation
STANDARD MOUNTING	DIN 41494 10mm. square slot
STANDARD FINISH	Powder Coating
STANDARD COLOR	Dark Grey and Light Grey or Black
STATIC LOAD	40 Kgs

## ▶ Product Codes and Dimensions

PART CODE	Total Height in MM (H)	Usable Height in U (H)	Total Width in MM (W)	Usable Width in Inches (W)	Total Depth in MM (D)	Usable Depth in MM (D)
MRS-SS-5550-09U	480	09U	550	19"	500	450

1U = 44.45 mm / 1.75 Inch

### Note:

1. Other models can be manufactured on request.
2. It is recommended to distribute the load along with "U" space in the rack.
3. All dimensions are in mm.



## MODULAR RACK SYSTEMS PVT. LTD.

No. 189 & 190, Nadikerappa Industrial Estate, Hegganahalli, Vishwanedam Post,  
Bangalore-560 091 INDIA • Tel: +91 80 28365042 • Fax: +91 80 28367881  
Mobile: +91 9108220086 • Email: admin@mrsrack.com





# Innovations Customized

**MRS**<sup>®</sup>  
**MODULAR**  
RACK SYSTEMS PVT LTD

**WALL MOUNT  
RACKS**

**SS  
SERIES**





**MRS** offers a versatile range of single section wall mount racks to suit small secured network requirements.

Wall mount racks are the ideal solution where the floor space is a limitation, typical networking equipment like rotors, switches, patch panels, etc. are well accommodated in the rack.

**MRS** single section wall mount racks are fabricated out of C.R.C.A Steel Sheet CNC programmed, punched, bent, welded and powder coated with the highest quality under confirming Industrial, ISO 9001-2015 and 14001-2015 Standards. Manufacturing and quality management systems to ensure the highest quality product.

**MRS** single section wall mount racks are welded frame integrated with side panel / removable side panel, vented top cover with 2 fans and cable entry provision, bottom cover with ventilation and cable entry provision

associated with front toughened glass door along with lock and key and provision to mount on the wall.

**MRS** single section wall mount racks are available from 4 U to 15 U variants with 400, 500, and 600mm deep configuration.

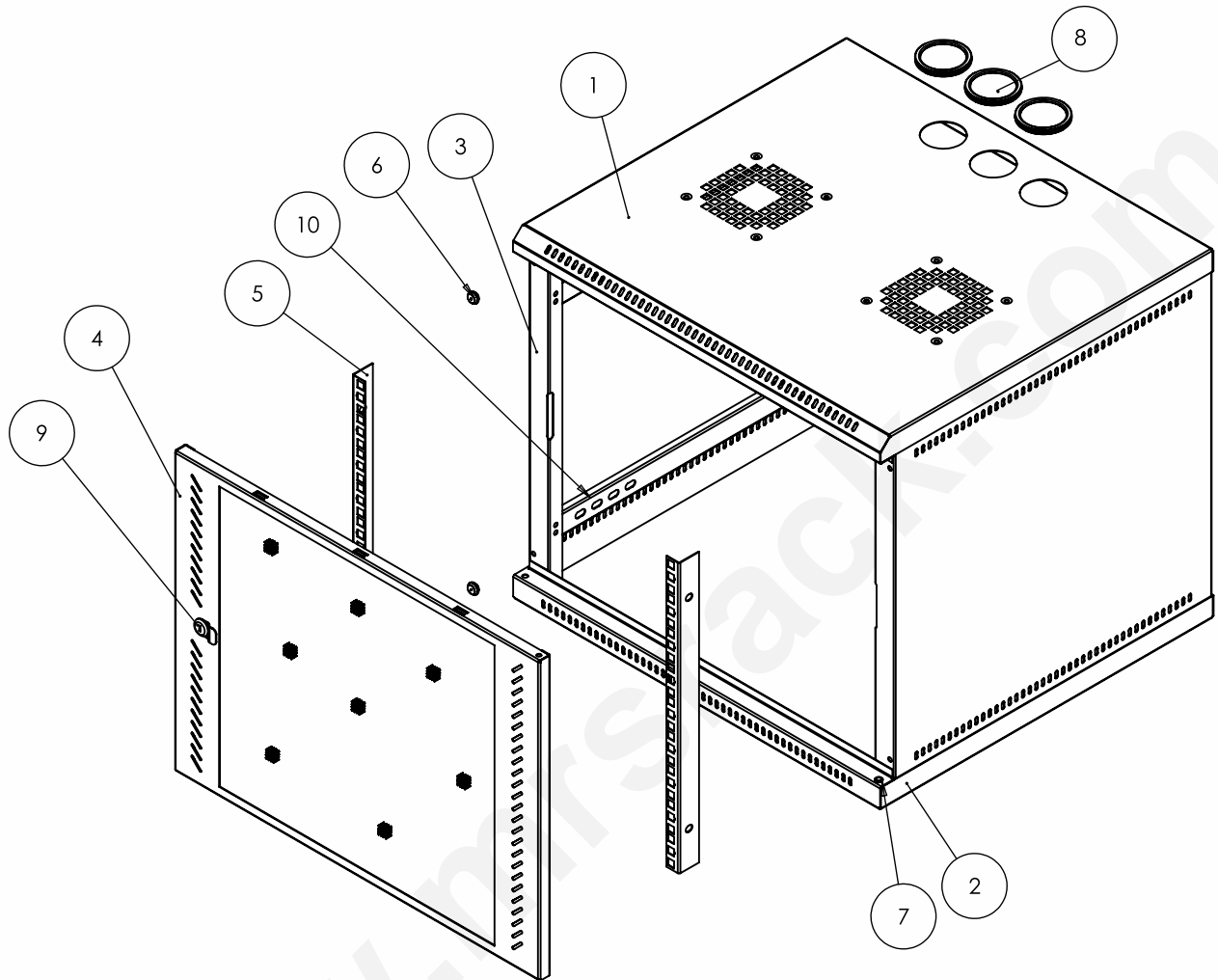

- 1 Top panel – Vented & provision for fan
- 2 Bottom panel - Vented
- 3 Side panel - Vented
- 4 Glass Door
- 5 L - Angle
- 6 Rubber Bumpons
- 7 Bushes (Nylon)
- 8 Rubber Grommet
- 9 Wall Mount Lock
- 10 C Channel

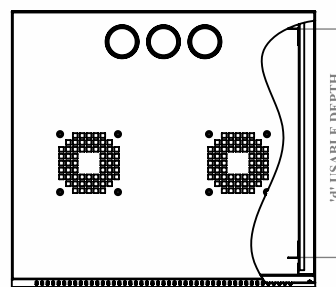

TOP VIEW

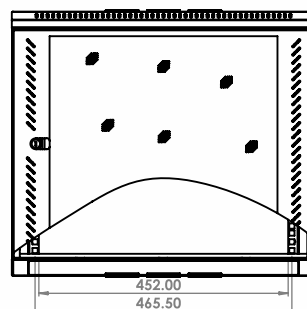

FRONT VIEW

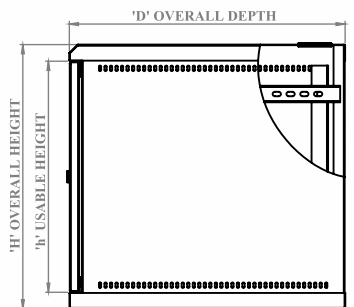

SIDE VIEW-RHS

# Product Features

- ◆ Conforms to DIN 41494 OR equivalent ISO Standard.
- ◆ Adjustable 4 nos. 19" angles with punched 10mm square holes and universal 12.7mm. 15.875. Alternating holes format offers for better mounting flexibility and maximizes usable mounting space.
- ◆ Depth adjustable mounting slots.
- ◆ Precision engineering capabilities and best efficient software configuration product technology provide the best product quality and fastest delivery in the industry.
- ◆ Top and bottom Panel with ventilation and cable entry facility.
- ◆ Provision to mount the cooling fans on the top panel.
- ◆ Powder coated finish with 7 Tank pretreatment process meeting ASTM standards.
- ◆ 100% assured compatibility with all equipment conforming to DIN 41494 (General industrial standard for equipment).

## Optional Accessories:

Grounding & Bonding Kit, Power Distribution Box, Instrument Cooling Fans, Cable Manager (Loop / Channel) Cantilever Shelves 250mm.

## ▶ Technical Data

BASIC FRAME	C.R.C.A Steel Sheet
CONSTRUCTION	Welded
SIDE PANELS	Integrated with top and bottom covers or (Removable type-on-request)
TOP AND BOTTOM PANEL	Vented with fan and cable entry provision
FRONT DOOR	Lockable toughened glass door with ventilation
STANDARD MOUNTING	DIN 41494 10mm. square slot
STANDARD FINISH	Powder Coating
STANDARD COLOR	Dark Grey and Light Grey or Black
STATIC LOAD	40 Kgs

## ▶ Product Codes and Dimensions

PART CODE	Total Height in MM (H)	Usable Height in U (H)	Total Width in MM (W)	Usable Width in Inches (W)	Total Depth in MM (D)	Usable Depth in MM (D)
MRS-SS-5550-12U	613	12U	550	19"	500	450

1U = 44.45 mm / 1.75 Inch

### Note:

1. Other models can be manufactured on request.
2. It is recommended to distribute the load along with "U" space in the rack.
3. All dimensions are in mm.



## MODULAR RACK SYSTEMS PVT. LTD.

No. 189 & 190, Nadikerappa Industrial Estate, Hegganahalli, Vishwaneedam Post,  
Bangalore-560 091 INDIA • Tel: +91 80 28365042 • Fax: +91 80 28367881  
Mobile: +91 9108220086 • Email: admin@mrsrack.com



# Innovations Customized

**MRS**<sup>®</sup>  
**MODULAR**  
RACK SYSTEMS PVT LTD

**WALL MOUNT  
RACKS**

**SS  
SERIES**



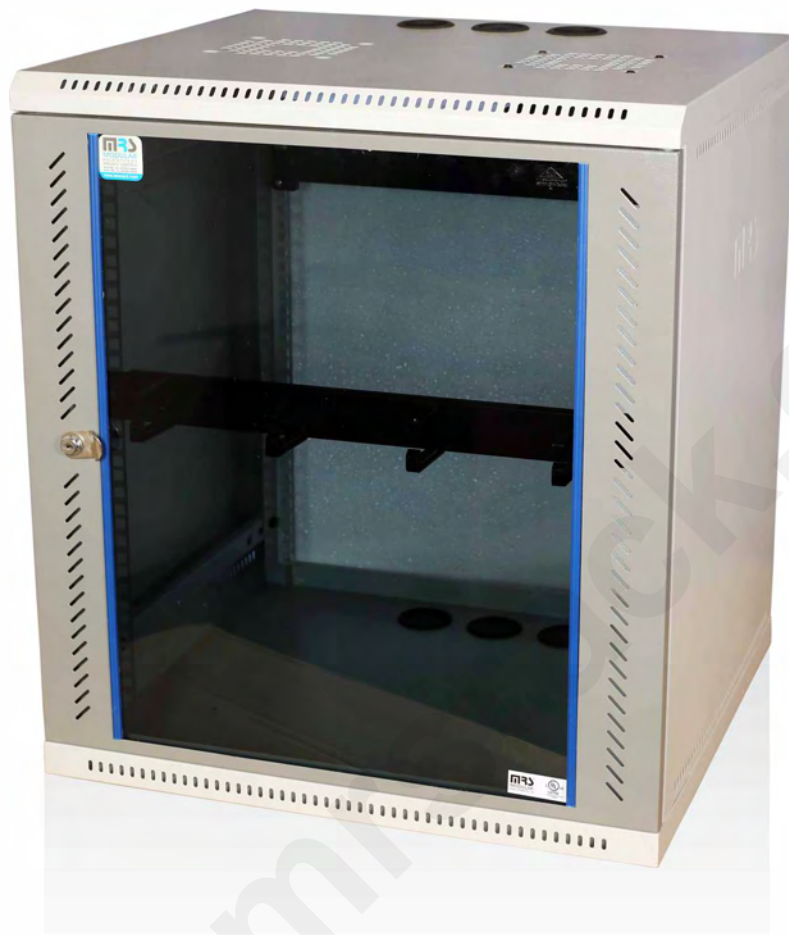

CERTIFIED

**MRS** offers a versatile range of single section wall mount racks to suit small secured network requirements.

Wall mount racks are the ideal solution where the floor space is a limitation, typical networking equipment like rotors, switches, patch panels, etc. are well accommodated in the rack.

**MRS** single section wall mount racks are fabricated out of C.R.C.A Steel Sheet CNC programmed, punched, bent, welded and powder coated with the highest quality under confirming Industrial, ISO 9001-2015 and 14001-2015 Standards. Manufacturing and quality management systems to ensure the highest quality product.

**MRS** single section wall mount racks are welded frame integrated with side panel / removable side panel, vented top cover with 2 fans and cable entry provision, bottom cover with ventilation and cable entry provision

associated with front toughened glass door along with lock and key and provision to mount on the wall.

**MRS** single section wall mount racks are available from 4 U to 15 U variants with 400, 500, and 600mm deep configuration.

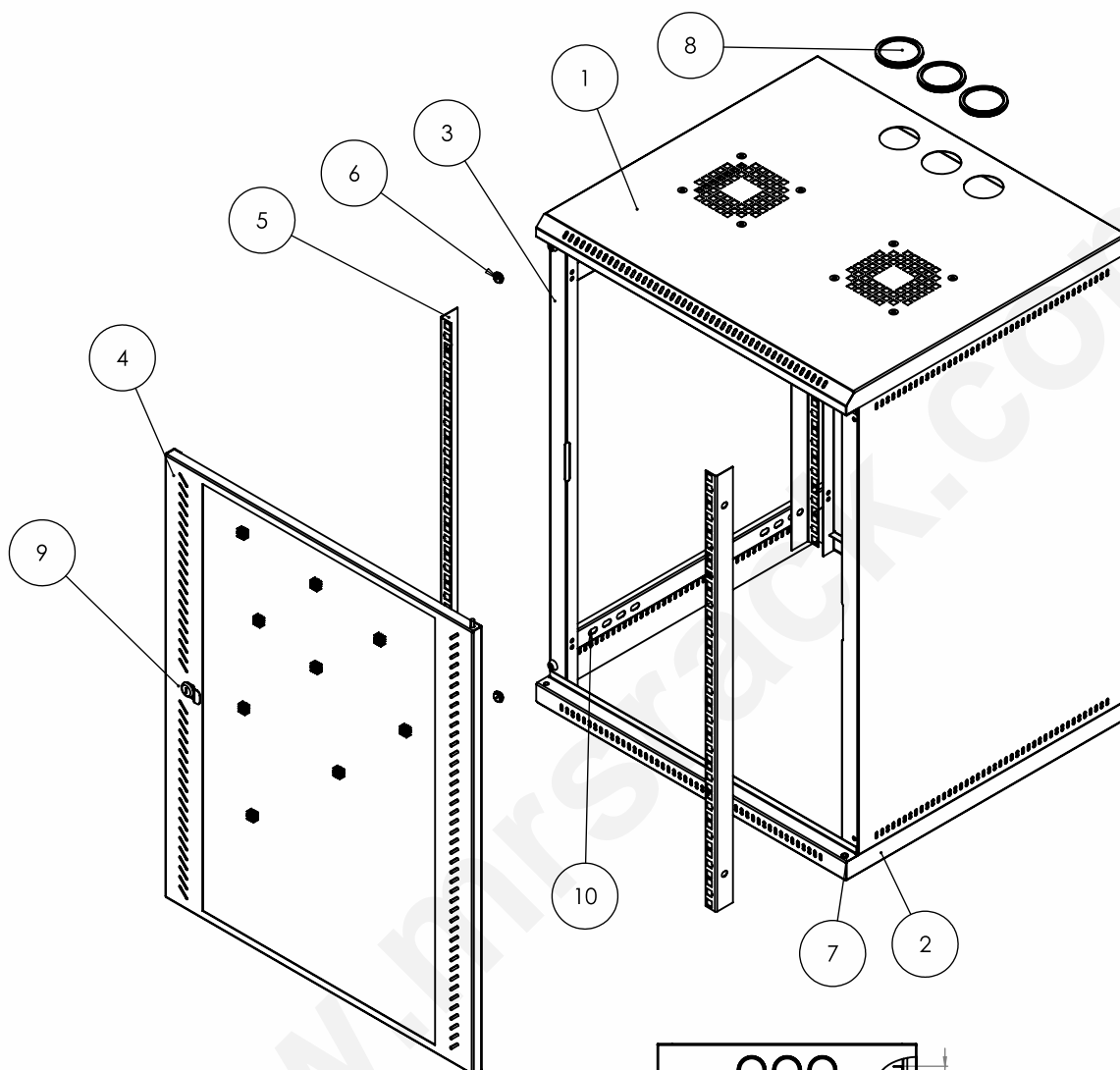

- 1 Top panel – Vented & provision for fan
- 2 Bottom panel - Vented
- 3 Side panel - Vented
- 4 Glass Door
- 5 L - Angle
- 6 Rubber Bumpons
- 7 Bushes (Nylon)
- 8 Rubber Grommet
- 9 Wall Mount Lock
- 10 C Channel

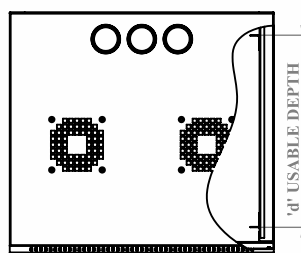

TOP VIEW

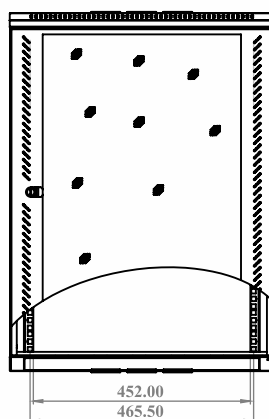

FRONT VIEW

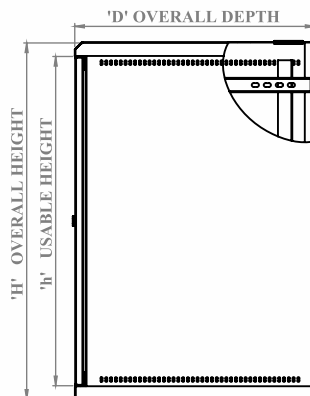

SIDE VIEW-RHS

# Product Features

- ◆ Conforms to DIN 41494 OR equivalent ISO Standard.
- ◆ Adjustable 4 nos. 19" angles with punched 10mm square holes and universal 12.7mm. 15.875. Alternating holes format offers for better mounting flexibility and maximizes usable mounting space.
- ◆ Depth adjustable mounting slots.
- ◆ Precision engineering capabilities and best efficient software configuration product technology provide the best product quality and fastest delivery in the industry.
- ◆ Top and bottom Panel with ventilation and cable entry facility.
- ◆ Provision to mount the cooling fans on the top panel.
- ◆ Powder coated finish with 7 Tank pretreatment process meeting ASTM standards.
- ◆ 100% assured compatibility with all equipment conforming to DIN 41494 (General industrial standard for equipment).

## Optional Accessories:

Grounding & Bonding Kit, Power Distribution Box, Instrument Cooling Fans, Cable Manager (Loop / Channel) Cantilever Shelves 250mm.

## ▶ Technical Data

BASIC FRAME	C.R.C.A Steel Sheet
CONSTRUCTION	Welded
SIDE PANELS	Integrated with top and bottom covers or (Removable type-on-request)
TOP AND BOTTOM PANEL	Vented with fan and cable entry provision
FRONT DOOR	Lockable toughened glass door with ventilation
STANDARD MOUNTING	DIN 41494 10mm. square slot
STANDARD FINISH	Powder Coating
STANDARD COLOR	Dark Grey and Light Grey or Black
STATIC LOAD	40 Kgs

## ▶ Product Codes and Dimensions

PART CODE	Total Height in MM (H)	Usable Height in U (H)	Total Width in MM (W)	Usable Width in Inches (W)	Total Depth in MM (D)	Usable Depth in MM (D)
MRS-SS-5550-15U	747	15U	550	19"	500	450

1U = 44.45 mm / 1.75 Inch

### Note:

1. Other models can be manufactured on request.
2. It is recommended to distribute the load along with "U" space in the rack.
3. All dimensions are in mm.



## MODULAR RACK SYSTEMS PVT. LTD.

No. 189 & 190, Nadikerappa Industrial Estate, Hegganahalli, Vishwaneedam Post,  
Bangalore-560 091 INDIA • Tel: +91 80 28365042 • Fax: +91 80 28367881  
Mobile: +91 9108220086 • Email: admin@mrsrack.com





# Innovations Customized

**MRS**<sup>®</sup>  
**MODULAR**  
RACK SYSTEMS PVT LTD

**WALL MOUNT  
RACKS**

**SS  
SERIES**





**MRS** offers a versatile range of single section wall mount racks to suit small secured network requirements.

Wall mount racks are the ideal solution where the floor space is a limitation, typical networking equipment like rotors, switches, patch panels, etc. are well accommodated in the rack.

**MRS** single section wall mount racks are fabricated out of C.R.C.A Steel Sheet CNC programmed, punched, bent, welded and powder coated with the highest quality under confirming Industrial, ISO 9001-2015 and 14001-2015 Standards. Manufacturing and quality management systems to ensure the highest quality product.

**MRS** single section wall mount racks are welded frame integrated with side panel / removable side panel, vented top cover with 2 fans and cable entry provision, bottom cover with ventilation and cable entry provision

associated with front toughened glass door along with lock and key and provision to mount on the wall.

**MRS** single section wall mount racks are available from 4 U to 15 U variants with 400, 500, and 600mm deep configuration.

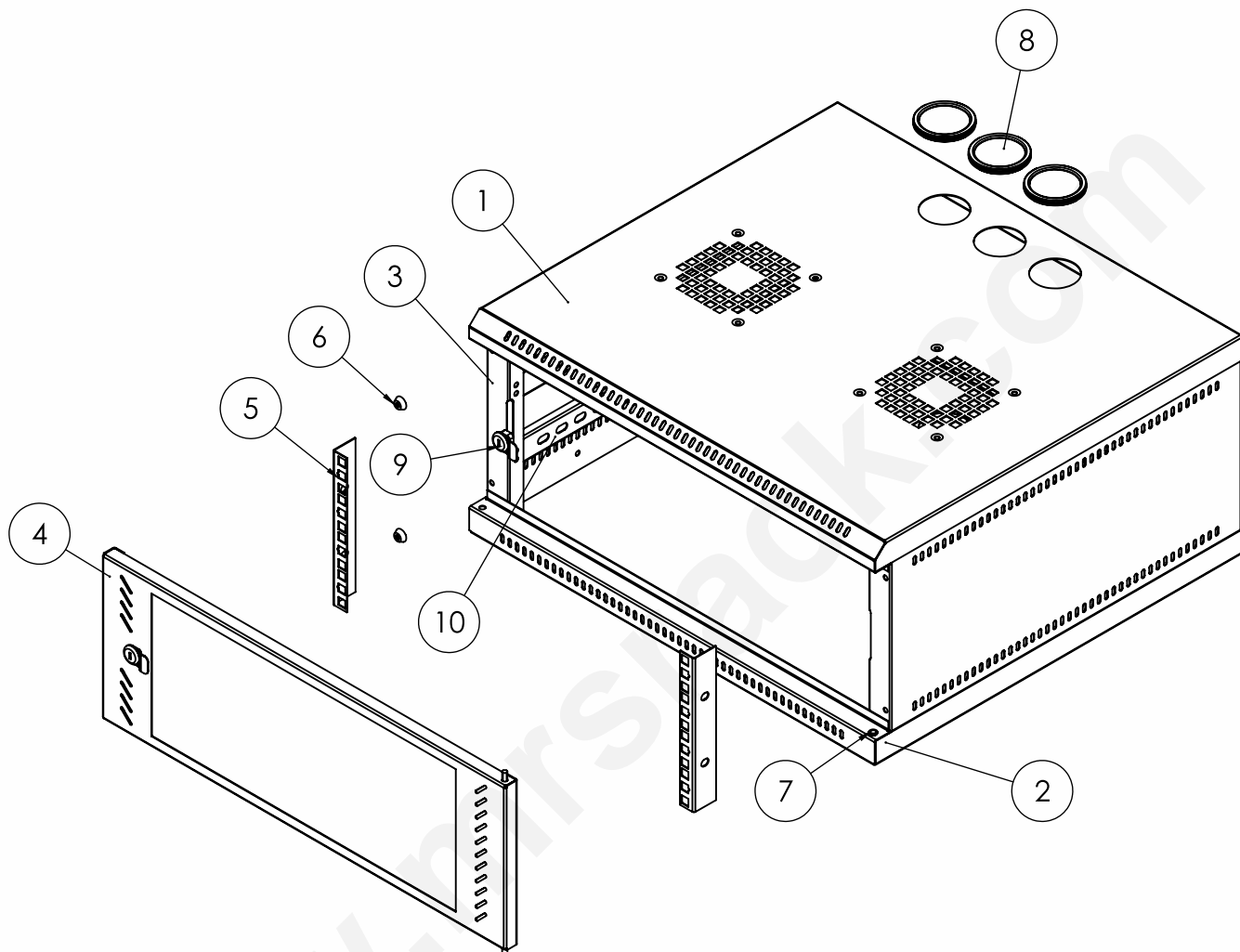

- 1 Top panel – Vented & provision for fan
- 2 Bottom panel - Vented
- 3 Side panel - Vented
- 4 Glass Door
- 5 L - Angle
- 6 Rubber Bumpons
- 7 Bushes (Nylon)
- 8 Rubber Grommet
- 9 Wall Mount Lock
- 10 C Channel

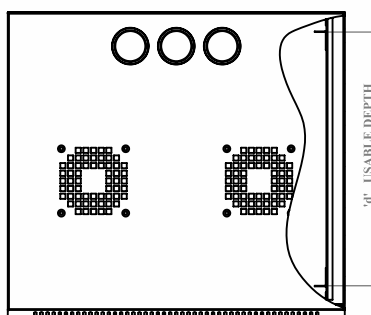

TOP VIEW

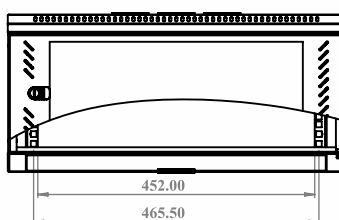

FRONT VIEW

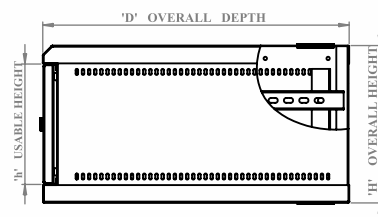

SIDE VIEW - RHS

# Product Features

- ◆ Conforms to DIN 41494 OR equivalent ISO Standard.
- ◆ Adjustable 4 nos. 19" angles with punched 10mm square holes and universal 12.7mm. 15.875. Alternating holes format offers for better mounting flexibility and maximizes usable mounting space.
- ◆ Depth adjustable mounting slots.
- ◆ Precision engineering capabilities and best efficient software configuration product technology provide the best product quality and fastest delivery in the industry.
- ◆ Top and bottom Panel with ventilation and cable entry facility.
- ◆ Provision to mount the cooling fans on the top panel.
- ◆ Powder coated finish with 7 Tank pretreatment process meeting ASTM standards.
- ◆ 100% assured compatibility with all equipment conforming to DIN 41494 (General industrial standard for equipment).

## Optional Accessories:

Grounding & Bonding Kit, Power Distribution Box, Instrument Cooling Fans, Cable Manager (Loop / Channel) Cantilever Shelves 250mm.

## ▶ Technical Data

BASIC FRAME	C.R.C.A Steel Sheet
CONSTRUCTION	Welded
SIDE PANELS	Integrated with top and bottom covers or (Removable type-on-request)
TOP AND BOTTOM PANEL	Vented with fan and cable entry provision
FRONT DOOR	Lockable toughened glass door with ventilation
STANDARD MOUNTING	DIN 41494 10mm. square slot
STANDARD FINISH	Powder Coating
STANDARD COLOR	Dark Grey and Light Grey or Black
STATIC LOAD	40 Kgs

## ▶ Product Codes and Dimensions

PART CODE	Total Height in MM (H)	Usable Height in U (H)	Total Width in MM (W)	Usable Width in Inches (W)	Total Depth in MM (D)	Usable Depth in MM (D)
MRS-SS-5560-04U	256	04U	550	19"	600	550

1U = 44.45 mm / 1.75 Inch

### Note:

1. Other models can be manufactured on request.
2. It is recommended to distribute the load along with "U" space in the rack.
3. All dimensions are in mm.



## MODULAR RACK SYSTEMS PVT. LTD.

No. 189 & 190, Nadikerappa Industrial Estate, Hegganahalli, Vishwaneedam Post,  
Bangalore-560 091 INDIA • Tel: +91 80 28365042 • Fax: +91 80 28367881  
Mobile: +91 9108220086 • Email: admin@mrsrack.com



# Innovations Customized

**MRS**<sup>®</sup>  
**MODULAR**  
RACK SYSTEMS PVT LTD

**WALL MOUNT  
RACKS**

**SS  
SERIES**



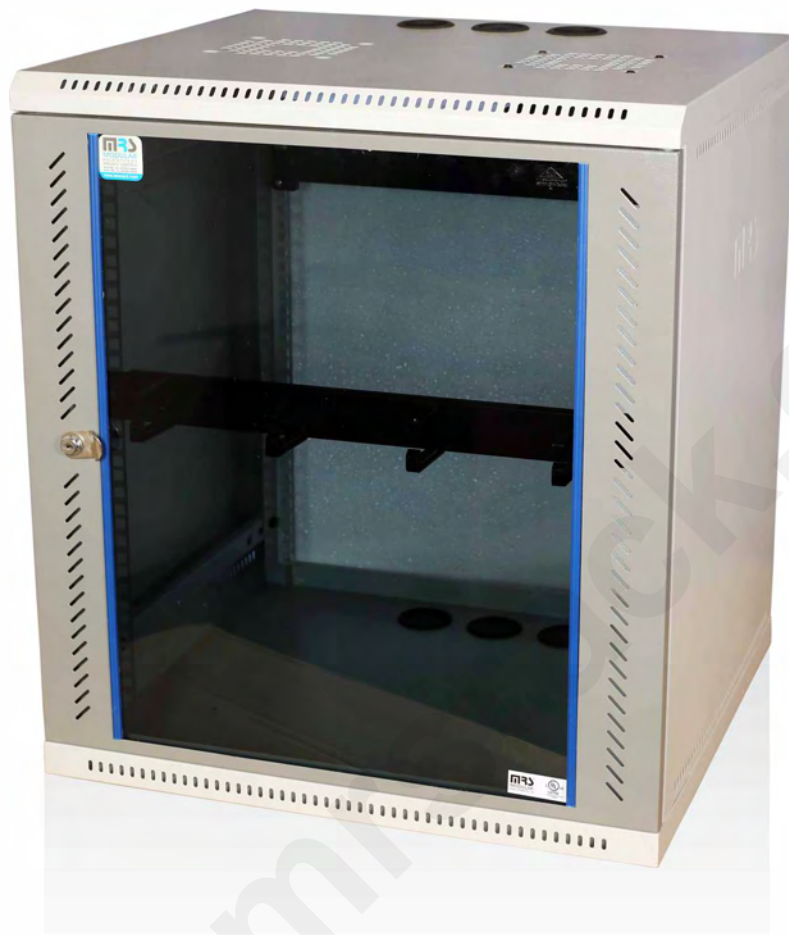

**MRS** offers a versatile range of single section wall mount racks to suit small secured network requirements.

Wall mount racks are the ideal solution where the floor space is a limitation, typical networking equipment like rotors, switches, patch panels, etc. are well accommodated in the rack.

**MRS** single section wall mount racks are fabricated out of C.R.C.A Steel Sheet CNC programmed, punched, bent, welded and powder coated with the highest quality under confirming Industrial, ISO 9001-2015 and 14001-2015 Standards. Manufacturing and quality management systems to ensure the highest quality product.

**MRS** single section wall mount racks are welded frame integrated with side panel / removable side panel, vented top cover with 2 fans and cable entry provision, bottom cover with ventilation and cable entry provision

associated with front toughened glass door along with lock and key and provision to mount on the wall.

**MRS** single section wall mount racks are available from 4 U to 15 U variants with 400, 500, and 600mm deep configuration.

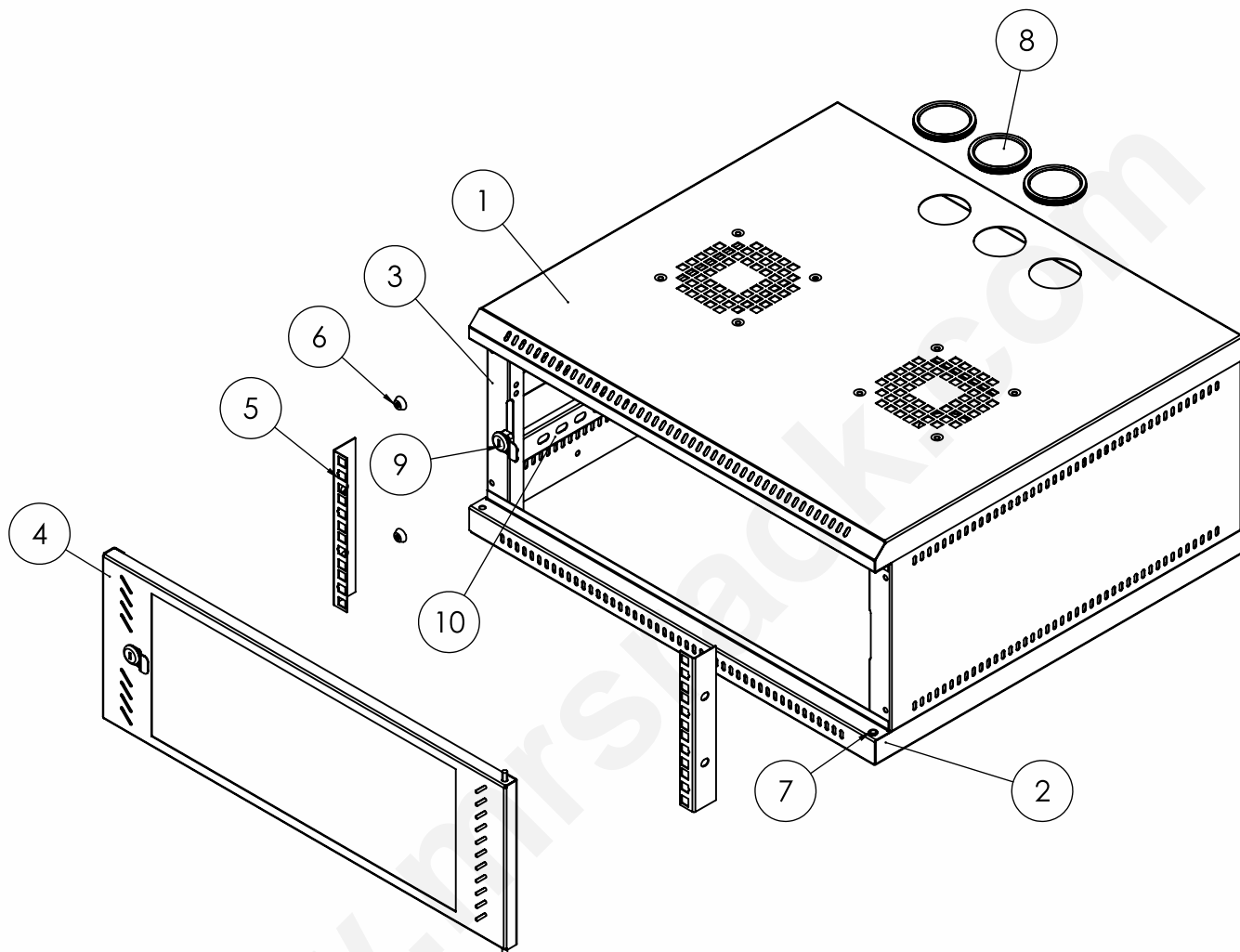

- 1 Top panel – Vented & provision for fan
- 2 Bottom panel - Vented
- 3 Side panel - Vented
- 4 Glass Door
- 5 L - Angle
- 6 Rubber Bumpons
- 7 Bushes (Nylon)
- 8 Rubber Grommet
- 9 Wall Mount Lock
- 10 C Channel

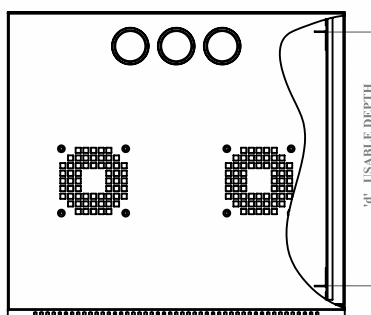

TOP VIEW

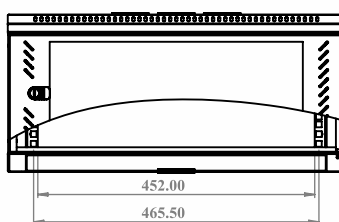

FRONT VIEW

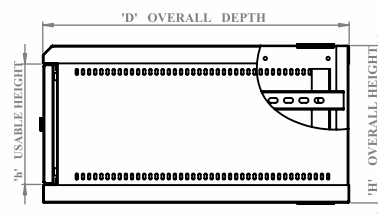

SIDE VIEW - RHS

# Product Features

- ◆ Conforms to DIN 41494 OR equivalent ISO Standard.
- ◆ Adjustable 4 nos. 19" angles with punched 10mm square holes and universal 12.7mm. 15.875. Alternating holes format offers for better mounting flexibility and maximizes usable mounting space.
- ◆ Depth adjustable mounting slots.
- ◆ Precision engineering capabilities and best efficient software configuration product technology provide the best product quality and fastest delivery in the industry.
- ◆ Top and bottom Panel with ventilation and cable entry facility.
- ◆ Provision to mount the cooling fans on the top panel.
- ◆ Powder coated finish with 7 Tank pretreatment process meeting ASTM standards.
- ◆ 100% assured compatibility with all equipment conforming to DIN 41494 (General industrial standard for equipment).

## Optional Accessories:

Grounding & Bonding Kit, Power Distribution Box, Instrument Cooling Fans, Cable Manager (Loop / Channel) Cantilever Shelves 250mm.

## ▶ Technical Data

BASIC FRAME	C.R.C.A Steel Sheet
CONSTRUCTION	Welded
SIDE PANELS	Integrated with top and bottom covers or (Removable type-on-request)
TOP AND BOTTOM PANEL	Vented with fan and cable entry provision
FRONT DOOR	Lockable toughened glass door with ventilation
STANDARD MOUNTING	DIN 41494 10mm. square slot
STANDARD FINISH	Powder Coating
STANDARD COLOR	Dark Grey and Light Grey or Black
STATIC LOAD	40 Kgs

## ▶ Product Codes and Dimensions

PART CODE	Total Height in MM (H)	Usable Height in U (H)	Total Width in MM (W)	Usable Width in Inches (W)	Total Depth in MM (D)	Usable Depth in MM (D)
<b>MRS-SS-5560-06U</b>	347	06U	550	19"	600	550

1U = 44.45 mm / 1.75 Inch

### Note:

1. Other models can be manufactured on request.
2. It is recommended to distribute the load along with "U" space in the rack.
3. All dimensions are in mm.



## MODULAR RACK SYSTEMS PVT. LTD.

No. 189 & 190, Nadikerappa Industrial Estate, Hegganahalli, Vishwanedam Post,  
Bangalore-560 091 INDIA • Tel: +91 80 28365042 • Fax: +91 80 28367881  
Mobile: +91 9108220086 • Email: admin@mrsrack.com





# Innovations Customized

**MRS**<sup>®</sup>  
**MODULAR**  
RACK SYSTEMS PVT LTD

**WALL MOUNT  
RACKS**

**SS  
SERIES**





**MRS** offers a versatile range of single section wall mount racks to suit small secured network requirements.

Wall mount racks are the ideal solution where the floor space is a limitation, typical networking equipment like rotors, switches, patch panels, etc. are well accommodated in the rack.

**MRS** single section wall mount racks are fabricated out of C.R.C.A Steel Sheet CNC programmed, punched, bent, welded and powder coated with the highest quality under confirming Industrial, ISO 9001-2015 and 14001-2015 Standards. Manufacturing and quality management systems to ensure the highest quality product.

**MRS** single section wall mount racks are welded frame integrated with side panel / removable side panel, vented top cover with 2 fans and cable entry provision, bottom cover with ventilation and cable entry provision

associated with front toughened glass door along with lock and key and provision to mount on the wall.

**MRS** single section wall mount racks are available from 4 U to 15 U variants with 400, 500, and 600mm deep configuration.

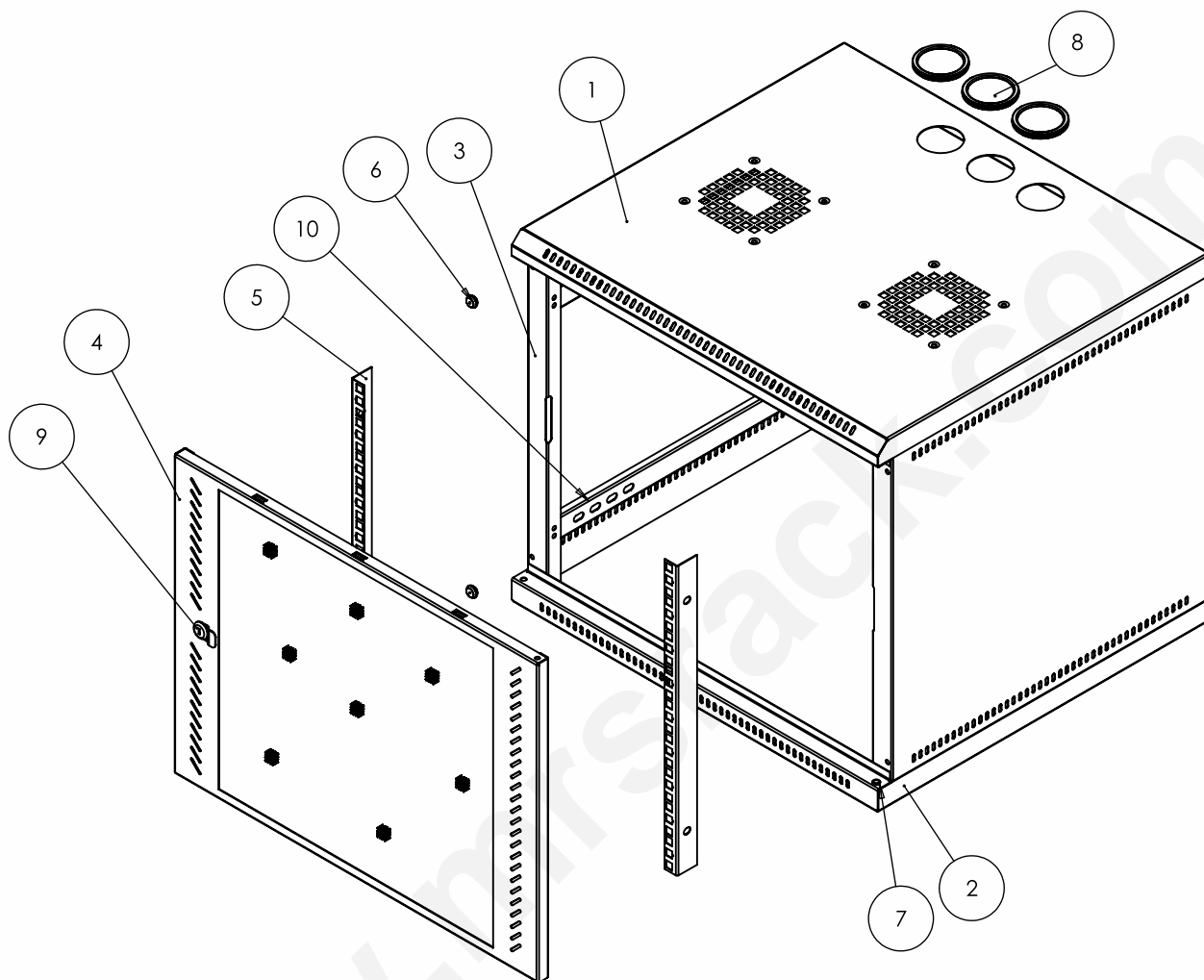

- 1 Top panel – Vented & provision for fan
- 2 Bottom panel - Vented
- 3 Side panel - Vented
- 4 Glass Door
- 5 L - Angle
- 6 Rubber Bumpons
- 7 Bushes (Nylon)
- 8 Rubber Grommet
- 9 Wall Mount Lock
- 10 C Channel

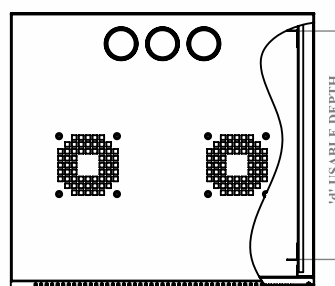

TOP VIEW

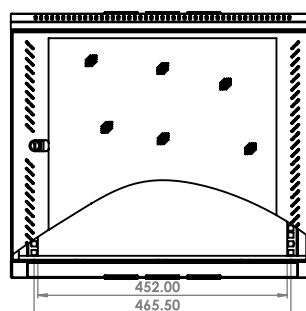

FRONT VIEW

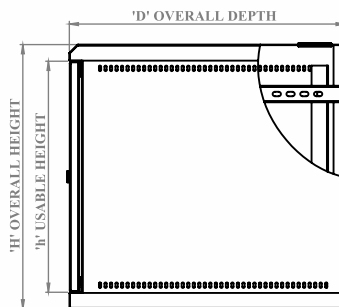

SIDE VIEW-RHS

# Product Features

- ◆ Conforms to DIN 41494 OR equivalent ISO Standard.
- ◆ Adjustable 4 nos. 19" angles with punched 10mm square holes and universal 12.7mm. 15.875. Alternating holes format offers for better mounting flexibility and maximizes usable mounting space.
- ◆ Depth adjustable mounting slots.
- ◆ Precision engineering capabilities and best efficient software configuration product technology provide the best product quality and fastest delivery in the industry.
- ◆ Top and bottom Panel with ventilation and cable entry facility.
- ◆ Provision to mount the cooling fans on the top panel.
- ◆ Powder coated finish with 7 Tank pretreatment process meeting ASTM standards.
- ◆ 100% assured compatibility with all equipment conforming to DIN 41494 (General industrial standard for equipment).

## Optional Accessories:

Grounding & Bonding Kit, Power Distribution Box, Instrument Cooling Fans, Cable Manager (Loop / Channel) Cantilever Shelves 250mm.

## ▶ Technical Data

BASIC FRAME	C.R.C.A Steel Sheet
CONSTRUCTION	Welded
SIDE PANELS	Integrated with top and bottom covers or (Removable type-on-request)
TOP AND BOTTOM PANEL	Vented with fan and cable entry provision
FRONT DOOR	Lockable toughened glass door with ventilation
STANDARD MOUNTING	DIN 41494 10mm. square slot
STANDARD FINISH	Powder Coating
STANDARD COLOR	Dark Grey and Light Grey or Black
STATIC LOAD	40 Kgs

## ▶ Product Codes and Dimensions

PART CODE	Total Height in MM (H)	Usable Height in U (H)	Total Width in MM (W)	Usable Width in Inches (W)	Total Depth in MM (D)	Usable Depth in MM (D)
MRS-SS-5560-09U	480	09U	550	19"	600	550

1U = 44.45 mm / 1.75 Inch

### Note:

1. Other models can be manufactured on request.
2. It is recommended to distribute the load along with "U" space in the rack.
3. All dimensions are in mm.



## MODULAR RACK SYSTEMS PVT. LTD.

No. 189 & 190, Nadikerappa Industrial Estate, Hegganahalli, Vishwanedam Post,  
Bangalore-560 091 INDIA • Tel: +91 80 28365042 • Fax: +91 80 28367881  
Mobile: +91 9108220086 • Email: admin@mrsrack.com



# Innovations Customized

**MRS**<sup>®</sup>  
**MODULAR**  
RACK SYSTEMS PVT LTD

**WALL MOUNT  
RACKS**

**SS  
SERIES**



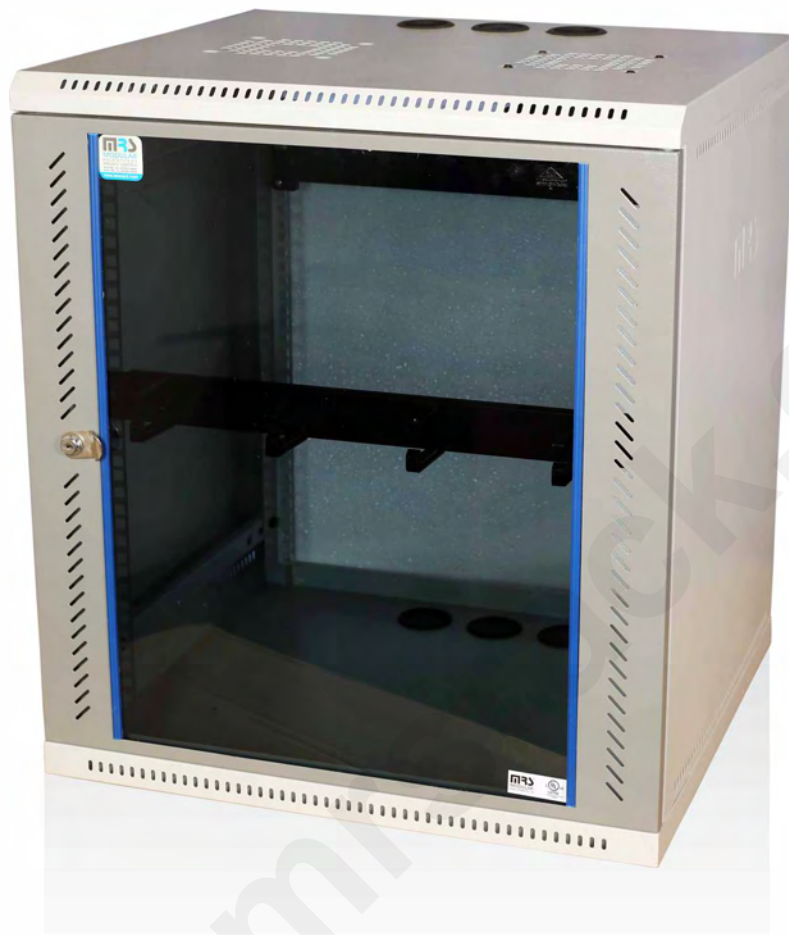

CERTIFIED

**MRS** offers a versatile range of single section wall mount racks to suit small secured network requirements.

Wall mount racks are the ideal solution where the floor space is a limitation, typical networking equipment like rotors, switches, patch panels, etc. are well accommodated in the rack.

**MRS** single section wall mount racks are fabricated out of C.R.C.A Steel Sheet CNC programmed, punched, bent, welded and powder coated with the highest quality under confirming Industrial, ISO 9001-2015 and 14001-2015 Standards. Manufacturing and quality management systems to ensure the highest quality product.

**MRS** single section wall mount racks are welded frame integrated with side panel / removable side panel, vented top cover with 2 fans and cable entry provision, bottom cover with ventilation and cable entry provision

associated with front toughened glass door along with lock and key and provision to mount on the wall.

**MRS** single section wall mount racks are available from 4 U to 15 U variants with 400, 500, and 600mm deep configuration.

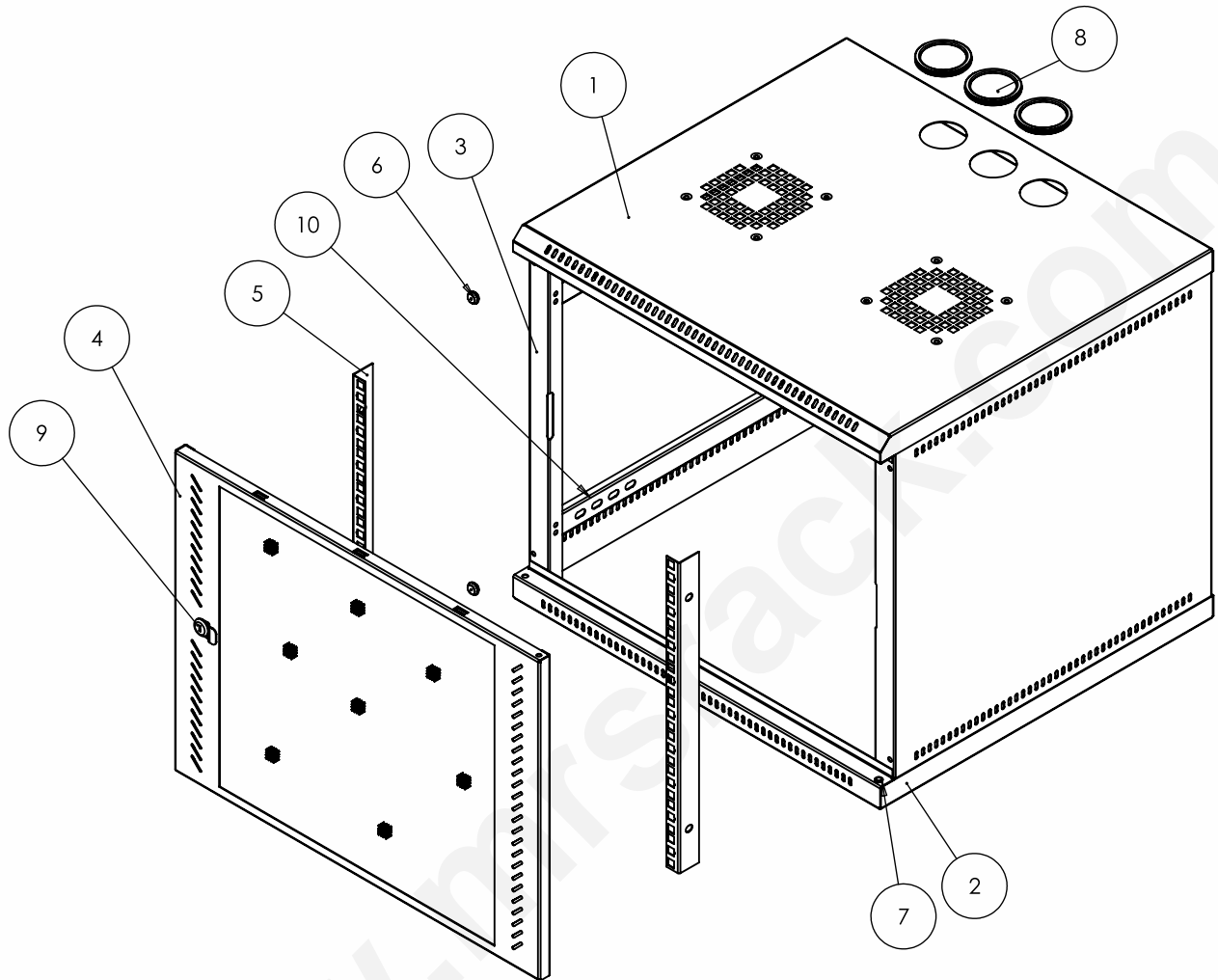

- 1 Top panel – Vented & provision for fan
- 2 Bottom panel - Vented
- 3 Side panel - Vented
- 4 Glass Door
- 5 L - Angle
- 6 Rubber Bumpons
- 7 Bushes (Nylon)
- 8 Rubber Grommet
- 9 Wall Mount Lock
- 10 C Channel

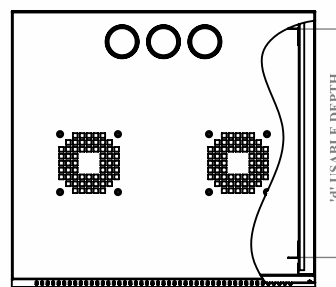

TOP VIEW

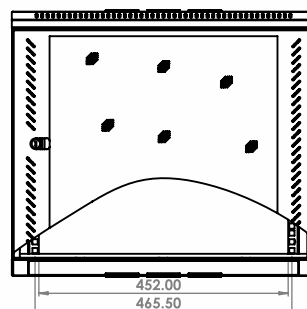

FRONT VIEW

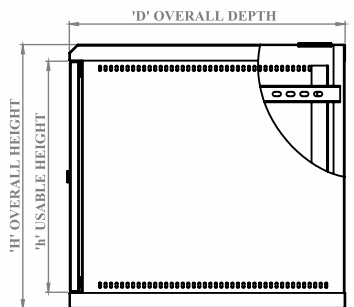

SIDE VIEW-RHS

# Product Features

- ◆ Conforms to DIN 41494 OR equivalent ISO Standard.
- ◆ Adjustable 4 nos. 19" angles with punched 10mm square holes and universal 12.7mm. 15.875. Alternating holes format offers for better mounting flexibility and maximizes usable mounting space.
- ◆ Depth adjustable mounting slots.
- ◆ Precision engineering capabilities and best efficient software configuration product technology provide the best product quality and fastest delivery in the industry.
- ◆ Top and bottom Panel with ventilation and cable entry facility.
- ◆ Provision to mount the cooling fans on the top panel.
- ◆ Powder coated finish with 7 Tank pretreatment process meeting ASTM standards.
- ◆ 100% assured compatibility with all equipment conforming to DIN 41494 (General industrial standard for equipment).

## Optional Accessories:

Grounding & Bonding Kit, Power Distribution Box, Instrument Cooling Fans, Cable Manager (Loop / Channel) Cantilever Shelves 250mm.

## ▶ Technical Data

BASIC FRAME	C.R.C.A Steel Sheet
CONSTRUCTION	Welded
SIDE PANELS	Integrated with top and bottom covers or (Removable type-on-request)
TOP AND BOTTOM PANEL	Vented with fan and cable entry provision
FRONT DOOR	Lockable toughened glass door with ventilation
STANDARD MOUNTING	DIN 41494 10mm. square slot
STANDARD FINISH	Powder Coating
STANDARD COLOR	Dark Grey and Light Grey or Black
STATIC LOAD	40 Kgs

## ▶ Product Codes and Dimensions

PART CODE	Total Height in MM (H)	Usable Height in U (H)	Total Width in MM (W)	Usable Width in Inches (W)	Total Depth in MM (D)	Usable Depth in MM (D)
<b>MRS-SS-5560-12U</b>	613	12U	550	19"	600	550

1U = 44.45 mm / 1.75 Inch

### Note:

1. Other models can be manufactured on request.
2. It is recommended to distribute the load along with "U" space in the rack.
3. All dimensions are in mm.



## MODULAR RACK SYSTEMS PVT. LTD.

No. 189 & 190, Nadikerappa Industrial Estate, Hegganahalli, Vishwaneedam Post,  
Bangalore-560 091 INDIA • Tel: +91 80 28365042 • Fax: +91 80 28367881  
Mobile: +91 9108220086 • Email: admin@mrsrack.com





# Innovations Customized

**MRS**<sup>®</sup>  
**MODULAR**  
RACK SYSTEMS PVT LTD

**WALL MOUNT  
RACKS**

**SS  
SERIES**



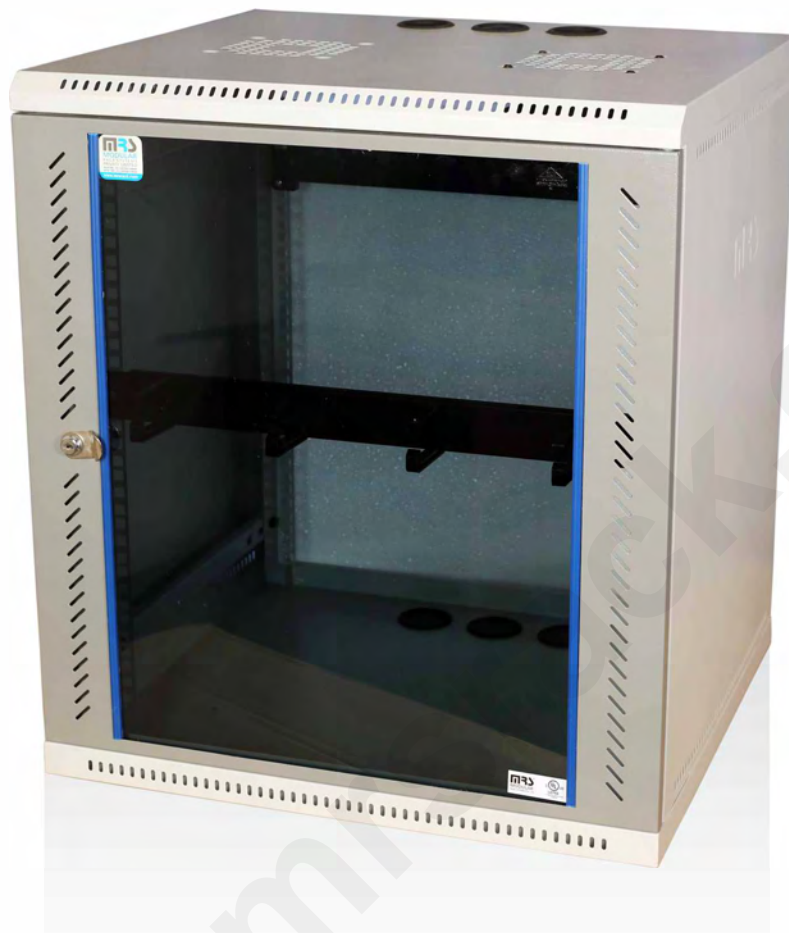

**MRS** offers a versatile range of single section wall mount racks to suit small secured network requirements.

Wall mount racks are the ideal solution where the floor space is a limitation, typical networking equipment like rotors, switches, patch panels, etc. are well accommodated in the rack.

**MRS** single section wall mount racks are fabricated out of C.R.C.A Steel Sheet CNC programmed, punched, bent, welded and powder coated with the highest quality under confirming Industrial, ISO 9001-2015 and 14001-2015 Standards. Manufacturing and quality management systems to ensure the highest quality product.

**MRS** single section wall mount racks are welded frame integrated with side panel / removable side panel, vented top cover with 2 fans and cable entry provision, bottom cover with ventilation and cable entry provision

associated with front toughened glass door along with lock and key and provision to mount on the wall.

**MRS** single section wall mount racks are available from 4 U to 15 U variants with 400, 500, and 600mm deep configuration.

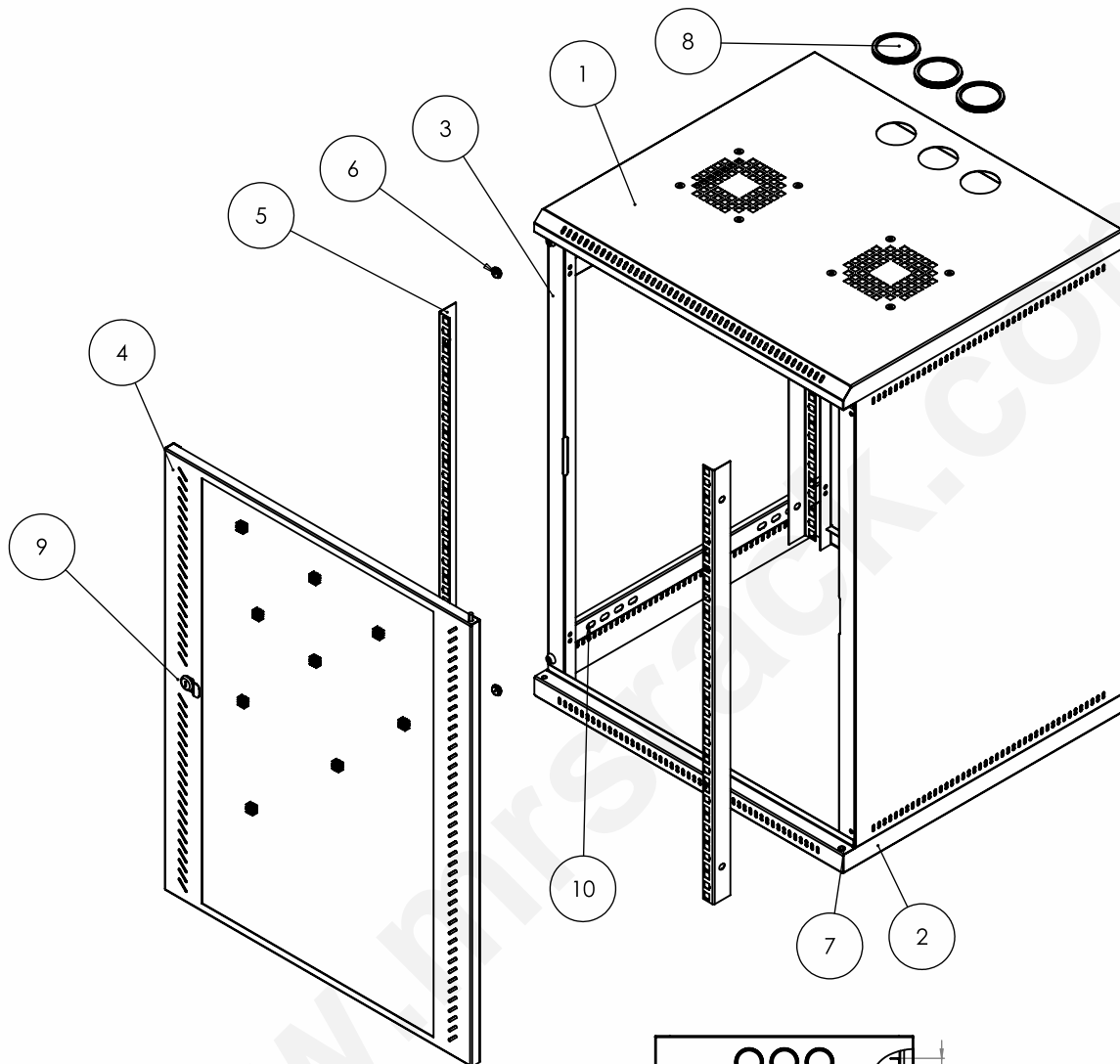

- 1 Top panel – Vented & provision for fan
- 2 Bottom panel - Vented
- 3 Side panel - Vented
- 4 Glass Door
- 5 L - Angle
- 6 Rubber Bumpons
- 7 Bushes (Nylon)
- 8 Rubber Grommet
- 9 Wall Mount Lock
- 10 C Channel

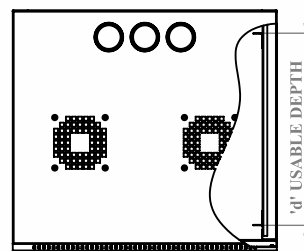

TOP VIEW

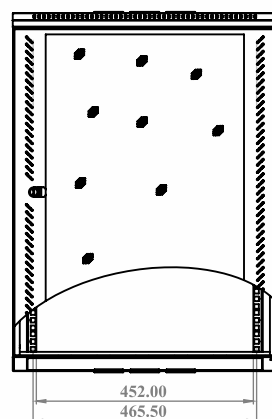

FRONT VIEW

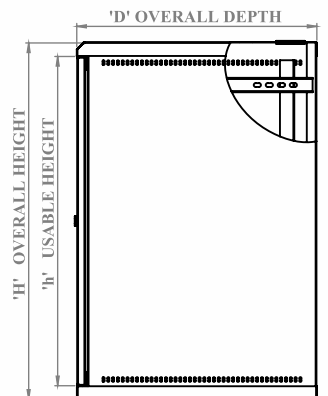

SIDE VIEW-RHS

# Product Features

- ◆ Conforms to DIN 41494 OR equivalent ISO Standard.
- ◆ Adjustable 4 nos. 19" angles with punched 10mm square holes and universal 12.7mm. 15.875. Alternating holes format offers for better mounting flexibility and maximizes usable mounting space.
- ◆ Depth adjustable mounting slots.
- ◆ Precision engineering capabilities and best efficient software configuration product technology provide the best product quality and fastest delivery in the industry.
- ◆ Top and bottom Panel with ventilation and cable entry facility.
- ◆ Provision to mount the cooling fans on the top panel.
- ◆ Powder coated finish with 7 Tank pretreatment process meeting ASTM standards.
- ◆ 100% assured compatibility with all equipment conforming to DIN 41494 (General industrial standard for equipment).

## Optional Accessories:

Grounding & Bonding Kit, Power Distribution Box, Instrument Cooling Fans, Cable Manager (Loop / Channel) Cantilever Shelves 250mm.

## ▶ Technical Data

BASIC FRAME	C.R.C.A Steel Sheet
CONSTRUCTION	Welded
SIDE PANELS	Integrated with top and bottom covers or (Removable type-on-request)
TOP AND BOTTOM PANEL	Vented with fan and cable entry provision
FRONT DOOR	Lockable toughened glass door with ventilation
STANDARD MOUNTING	DIN 41494 10mm. square slot
STANDARD FINISH	Powder Coating
STANDARD COLOR	Dark Grey and Light Grey or Black
STATIC LOAD	40 Kgs

## ▶ Product Codes and Dimensions

PART CODE	Total Height in MM (H)	Usable Height in U (H)	Total Width in MM (W)	Usable Width in Inches (W)	Total Depth in MM (D)	Usable Depth in MM (D)
<b>MRS-SS-5560-15U</b>	747	15U	550	19"	600	550

1U = 44.45 mm / 1.75 Inch

### Note:

1. Other models can be manufactured on request.
2. It is recommended to distribute the load along with "U" space in the rack.
3. All dimensions are in mm.



## MODULAR RACK SYSTEMS PVT. LTD.

No. 189 & 190, Nadikerappa Industrial Estate, Hegganahalli, Vishwaneedam Post,  
Bangalore-560 091 INDIA • Tel: +91 80 28365042 • Fax: +91 80 28367881  
Mobile: +91 9108220086 • Email: admin@mrsrack.com

